

**ANSI/ASHRAE Standard 62.1-2010**  
(Supersedes ANSI/ASHRAE Standard 62.1-2007)  
Includes ANSI/ASHRAE addenda listed in Appendix J



# ASHRAE STANDARD

## Ventilation for Acceptable Indoor Air Quality

See Appendix J for approval dates by the ASHRAE Standards Committee the ASHRAE Board of Directors, and the American National Standards Institute.

This standard is under continuous maintenance by a Standing Standard Project Committee (SSPC) for which the Standards Committee has established a documented program for regular publication of addenda or revisions, including procedures for timely, documented, consensus action on requests for change to any part of the standard. The change submittal form, instructions, and deadlines may be obtained in electronic form from the ASHRAE Web site ([www.ashrae.org](http://www.ashrae.org)) or in paper form from the Manager of Standards. The latest edition of an ASHRAE Standard may be purchased from the ASHRAE Web site ([www.ashrae.org](http://www.ashrae.org)) or from ASHRAE Customer Service, 1791 Tullie Circle, NE, Atlanta, GA 30329-2305. E-mail: [orders@ashrae.org](mailto:orders@ashrae.org). Fax: 404-321-5478. Telephone: 404-636-8400 (worldwide), or toll free 1-800-527-4723 (for orders in US and Canada). For reprint permission, go to [www.ashrae.org/permissions](http://www.ashrae.org/permissions).

© Copyright 2010 American Society of Heating, Refrigerating and Air-Conditioning Engineers, Inc.

ISSN 1041-2336



**American Society of Heating, Refrigerating  
and Air-Conditioning Engineers, Inc.**  
1791 Tullie Circle NE, Atlanta, GA 30329  
[www.ashrae.org](http://www.ashrae.org)

**ASHRAE Standing Standard Project Committee 62.1**  
**Cognizant TC: TC 4.3, Ventilation Requirements and Infiltration**

**SPLS Liaison: Robert G. Baker**

**Staff Liaison: Mark Weber**

Roger L. Hedrick, *Chair*  
John K. McFarland, *Vice-Chair*  
Dennis A. Stanke, *Chair (2007–2009)*  
Leon E. Alevantis  
Michael G. Apte  
David C. Bixby  
Hoy R. Bohanon, Jr.  
Gregory Brunner  
Mark P. Buttner  
Waller S. Clements  
David R. Conover  
Leonard A. Damiano  
Richard A. Danks  
Francis J. Fisher, Jr.

Vincent T. Galatro  
Francis Michael Gallo  
John R. Girman  
Diane I. Green  
Donald C. Herrmann  
Thomas P. Houston  
Eli P. Howard, III  
Roger L. Howard  
Wayne M. Lawton  
Don MacMillan  
Chris R. Magee  
Carl A. Marbery  
James Patrick McClendon  
Adam S. Muliawan  
Christopher O. Muller

Darren B. Meyers  
Lisa J. Rogers  
Duane P. Rothstein  
Lawrence J. Schoen  
Chandra Sekhar  
Harris M. Sheinman  
Dennis M. Siano  
Jeffrey K. Smith  
Anthony J. Spata  
Christine Q. Sun  
Jan Sundell  
Wayne R. Thomann  
Dilip Y. Vyavaharkar  
Michael W. Woodford

---

**ASHRAE STANDARDS COMMITTEE 2009–2010**

Steven T. Bushby, *Chair*  
H. Michael Newman, *Vice-Chair*  
Douglass S. Abramson  
Robert G. Baker  
Michael F. Beda  
Hoy R. Bohanon, Jr.  
Kenneth W. Cooper  
K. William Dean  
Martin Dieryckx  
Allan B. Fraser  
Nadar R. Jayaraman  
Byron W. Jones  
Jay A. Kohler  
Carol E. Marriott

Merle F. McBride  
Frank Myers  
Janice C. Peterson  
Douglas T. Reindl  
Lawrence J. Schoen  
Boggarm S. Setty  
Bodh R. Subherwal  
James R. Tauby  
James K. Vallort  
William F. Walter  
Michael W. Woodford  
Craig P. Wray  
Wayne R. Reedy, *BOD ExO*  
Thomas E. Watson, *CO*

*Stephanie Reiniche, Manager of Standards*

---

**SPECIAL NOTE**

This American National Standard (ANS) is a national voluntary consensus standard developed under the auspices of the American Society of Heating, Refrigerating and Air-Conditioning Engineers (ASHRAE). *Consensus* is defined by the American National Standards Institute (ANSI), of which ASHRAE is a member and which has approved this standard as an ANS, as “substantial agreement reached by directly and materially affected interest categories. This signifies the concurrence of more than a simple majority, but not necessarily unanimity. Consensus requires that all views and objections be considered, and that an effort be made toward their resolution.” Compliance with this standard is voluntary until and unless a legal jurisdiction makes compliance mandatory through legislation.

ASHRAE obtains consensus through participation of its national and international members, associated societies, and public review.

ASHRAE Standards are prepared by a Project Committee appointed specifically for the purpose of writing the Standard. The Project Committee Chair and Vice-Chair must be members of ASHRAE; while other committee members may or may not be ASHRAE members, all must be technically qualified in the subject area of the Standard. Every effort is made to balance the concerned interests on all Project Committees.

The Manager of Standards of ASHRAE should be contacted for:

- a. interpretation of the contents of this Standard,
- b. participation in the next review of the Standard,
- c. offering constructive criticism for improving the Standard, or
- d. permission to reprint portions of the Standard.

**DISCLAIMER**

ASHRAE uses its best efforts to promulgate Standards and Guidelines for the benefit of the public in light of available information and accepted industry practices. However, ASHRAE does not guarantee, certify, or assure the safety or performance of any products, components, or systems tested, installed, or operated in accordance with ASHRAE's Standards or Guidelines or that any tests conducted under its Standards or Guidelines will be nonhazardous or free from risk.

**ASHRAE INDUSTRIAL ADVERTISING POLICY ON STANDARDS**

ASHRAE Standards and Guidelines are established to assist industry and the public by offering a uniform method of testing for rating purposes, by suggesting safe practices in designing and installing equipment, by providing proper definitions of this equipment, and by providing other information that may serve to guide the industry. The creation of ASHRAE Standards and Guidelines is determined by the need for them, and conformance to them is completely voluntary.

In referring to this Standard or Guideline and in marking of equipment and in advertising, no claim shall be made, either stated or implied, that the product has been approved by ASHRAE.

## CONTENTS

### ANSI/ASHRAE Standard 62.1-2010, Ventilation for Acceptable Indoor Air Quality

SECTION	PAGE
Foreword.....	2
1 Purpose .....	3
2 Scope .....	3
3 Definitions.....	3
4 Outdoor Air Quality .....	5
5 Systems and Equipment.....	5
6 Procedures .....	10
7 Construction and System Start-Up.....	18
8 Operations and Maintenance .....	19
9 References .....	21
Normative Appendix A: Multiple-Zone Systems .....	22
Informative Appendix B: Summary of Selected Air Quality Guidelines .....	25
Informative Appendix C: Rationale for Minimum Physiological Requirements for Respiration Air Based on CO <sub>2</sub> Concentration.....	37
Informative Appendix D: Acceptable Mass Balance Equations for Use with the IAQ Procedure .....	39
Informative Appendix E: Information on Selected National Standards and Guidelines for PM <sub>10</sub> , PM <sub>2.5</sub> , and Ozone .....	41
Informative Appendix F: Separation of Exhaust Outlets and Outdoor Air Intakes .....	42
Informative Appendix G: Application and Compliance.....	44
Informative Appendix H: Documentation .....	46
Informative Appendix I: National Ambient Air Quality Standards.....	49
Informative Appendix J: Addenda Description Information.....	50

#### NOTE

Approved addenda, errata, or interpretations for this standard can be downloaded free of charge from the ASHRAE Web site at [www.ashrae.org/technology](http://www.ashrae.org/technology).

**(This foreword is not part of this standard. It is merely informative and does not contain requirements necessary for conformance to the standard. It has not been processed according to the ANSI requirements for a standard and may contain material that has not been subject to public review or a consensus process. Unresolved objectors on informative material are not offered the right to appeal at ASHRAE or ANSI.)**

## FOREWORD

*ANSI/ASHRAE Standard 62.1-2010 is the latest edition of Standard 62.1. The 2010 edition combines Standard 62.1-2007 and the 20 approved and published addenda to the 2007 edition, thereby providing an easy-to-use consolidated standard. Specific information on the contents of each addendum and approval dates for each addendum are included in Informative Appendix J at the end of this standard.*

*First published in 1973 as Standard 62, Standard 62.1 is now updated on a regular basis using ASHRAE's continuous maintenance procedures. According to these procedures, Standard 62.1 is continuously revised by addenda that are publicly reviewed, approved by ASHRAE and ANSI, and published in a Supplement approximately 18 months after each new edition of the standard, or in a new, complete edition of the standard, published every three years.*

*Standard 62.1 has undergone some key changes over the years, reflecting the ever-expanding body of knowledge, experience, and research related to ventilation and air quality. While the purpose of the standard has remained consistent—to specify minimum ventilation rates and other measures intended to provide indoor air quality that is acceptable to human occupants and that minimizes adverse health effects—the means of achieving this goal have evolved. In its first edition the standard adopted a prescriptive approach to ventilation by specifying both minimum and recommended outdoor airflow rates to obtain acceptable indoor air quality for a variety of indoor spaces. In its 1981 edition, the standard reduced minimum outdoor airflow rates and introduced an alternative performance-based approach, the Indoor Air Quality (IAQ) Procedure, which allowed for the calculation of the amount of outdoor air necessary to maintain the levels of indoor air contaminants below recommended limits. Today the standard still retains the two procedures for ventilation design, the IAQ Procedure and the Ventilation Rate Procedure (VRP).*

*In its 1989 edition, and in response to a growing number of buildings with apparent indoor air quality problems, the standard increased minimum outdoor airflow rates significantly and introduced a requirement for finding outdoor air intake flow requirements for multiple-zone, recirculating systems. The 1999 and 2001 editions made several minor changes and clarifications that did not impact the minimum required outdoor airflow rates. In its 2004 edition—the last time the standard was published in its entirety—the standard modified the IAQ Procedure to improve enforceability, but more significantly, it modified the Ventilation Rate Procedure, changing both the minimum outdoor airflow rates and the procedures for calculating both zone-level and system-level outdoor airflow rates. The 2007 edition of the standard provided*

*some significant updates, but the changes primarily focused on usability and clarity.*

*The 2010 edition of the standard revises and improves it in several ways. A number of changes remove inconsistencies within the standard and improve clarity. Significant changes include:*

- *Deletes Section 6.2.9, which had addressed ventilation in areas with smoking. Ventilation for such spaces is no longer covered by the standard.*
- *Provides minimum requirements to clarify when ventilation systems must be operated.*
- *Relocates natural ventilation requirements to a new Section 6.4, adding a prescriptive Natural Ventilation Procedure to the existing Ventilation Rate Procedure in Section 6.2 and IAQ Procedure in Section 6.3. The standard also now requires that most buildings designed to meet the natural ventilation requirements include a mechanical ventilation system designed to meet the VRP or IAQ Procedure requirements; mechanical system operation must be activated whenever conditions preclude operation of the natural ventilation system (e.g., due to thermal comfort, noise, security, or other issues).*
- *Relocates Table 6-4 and other requirements related to exhaust systems to a new Section 6.5, since exhaust requirements apply to all buildings, regardless of the procedure used to determine outdoor air intake flow rates.*
- *Revises the IAQ Procedure to make it more robust. In Informative Appendix B, provides a table of volatile organic compounds that designers might want to consider as possible contaminants of concern. To encourage designers to consider “additivity” (a basic consideration in the prescriptive VRP) when applying the IAQ Procedure, some guidance from the ACGIH has been included in the informative text.*
- *Adds additional requirements related to the design of demand-controlled ventilation systems.*
- *Revises requirements for separation of outdoor air intakes from exhaust and relief air outlets by using Classes of Air already defined in the standard rather than descriptions of the air quality.*
- *Adds some occupancy categories to the ventilation rate table (Table 6-1) and revises ventilation rates for a few occupancy categories.*
- *Deletes ventilation requirements for health care spaces since they are now covered by ASHRAE/ASHE Standard 170-2008, Ventilation of Health Care Facilities.*
- *Adds minimum filtration requirements related to PM<sub>2.5</sub>, and changes minimum air cleaning requirements related to ozone to reflect changes in the U.S. EPA's ozone reporting procedures. Table 4-1 is moved to an informative appendix to facilitate updates when the EPA makes changes to the NAAQS.*

*For more specific information on these changes and on other revisions made to the standard by other addenda, refer to Informative Appendix J at the end of this standard. Users of*

*the standard are encouraged to use the continuous maintenance procedure to suggest changes for further improvements. A form for submitting change proposals is included in the back of this edition. The project committee for Standard 62.1 will take formal action on all change proposals received.*

## 1. PURPOSE

**1.1** The purpose of this standard is to specify minimum ventilation rates and other measures intended to provide indoor air quality that is acceptable to human occupants and that minimizes adverse health effects.

**1.2** This standard is intended for regulatory application to new buildings, additions to existing buildings, and those changes to existing buildings that are identified in the body of the standard.

**1.3** This standard is intended to be used to guide the improvement of indoor air quality in existing buildings.

## 2. SCOPE

**2.1** This standard applies to all spaces intended for human occupancy except those within single-family houses, multi-family structures of three stories or fewer above grade, vehicles, and aircraft.

**2.2** This standard defines requirements for ventilation and air-cleaning system design, installation, commissioning, and operation and maintenance.

**2.3** Additional requirements for laboratory, industrial, health care, and other spaces may be dictated by workplace and other standards, as well as by the processes occurring within the space.

**2.4** Although the standard may be applied to both new and existing buildings, the provisions of this standard are not intended to be applied retroactively when the standard is used as a mandatory regulation or code.

**2.5** This standard does not prescribe specific ventilation rate requirements for spaces that contain smoking or that do not meet the requirements in the standard for separation from spaces that contain smoking.

**2.6** Ventilation requirements of this standard are based on chemical, physical, and biological contaminants that can affect air quality.

**2.7** Consideration or control of thermal comfort is not included.

**2.8** This standard contains requirements, in addition to ventilation, related to certain sources, including outdoor air, construction processes, moisture, and biological growth.

**2.9** Acceptable indoor air quality may not be achieved in all buildings meeting the requirements of this standard for one or more of the following reasons:

a. because of the diversity of sources and contaminants in indoor air;

- b. because of the many other factors that may affect occupant perception and acceptance of indoor air quality, such as air temperature, humidity, noise, lighting, and psychological stress;
- c. because of the range of susceptibility in the population; and
- d. because outdoor air brought into the building may be unacceptable or may not be adequately cleaned.

## 3. DEFINITIONS (SEE FIGURE 3.1)

**acceptable indoor air quality:** air in which there are no known contaminants at harmful concentrations as determined by cognizant authorities and with which a substantial majority (80% or more) of the people exposed do not express dissatisfaction.

**air-cleaning system:** a device or combination of devices applied to reduce the concentration of airborne contaminants, such as microorganisms, dusts, fumes, respirable particles, other particulate matter, gases, and/or vapors in air.

**air conditioning:** the process of treating air to meet the requirements of a conditioned space by controlling its temperature, humidity, cleanliness, and distribution.

**air, ambient:** the air surrounding a building; the source of outdoor air brought into a building.

**air, exhaust:** air removed from a space and discharged to outside the building by means of mechanical or natural ventilation systems.

**air, indoor:** the air in an enclosed occupiable space.

**air, makeup:** any combination of outdoor and transfer air intended to replace exhaust air and exfiltration.

**air, outdoor:** ambient air that enters a building through a ventilation system, through intentional openings for natural ventilation, or by infiltration.

**air, recirculated:** air removed from a space and reused as supply air.

**air, return:** air removed from a space to be then recirculated or exhausted.

**air, supply:** air delivered by mechanical or natural ventilation to a space, composed of any combination of outdoor air, recirculated air, or transfer air.

**air, transfer:** air moved from one indoor space to another.

**air, ventilation:** that portion of supply air that is outdoor air plus any recirculated air that has been treated for the purpose of maintaining acceptable indoor air quality.

**breathing zone:** the region within an occupied space between planes 3 and 72 in. (75 and 1800 mm) above the floor and more than 2 ft (600 mm) from the walls or fixed air-conditioning equipment.

**cognizant authority:** an agency or organization that has the expertise and jurisdiction to establish and regulate concentration limits for airborne contaminants; or an agency or

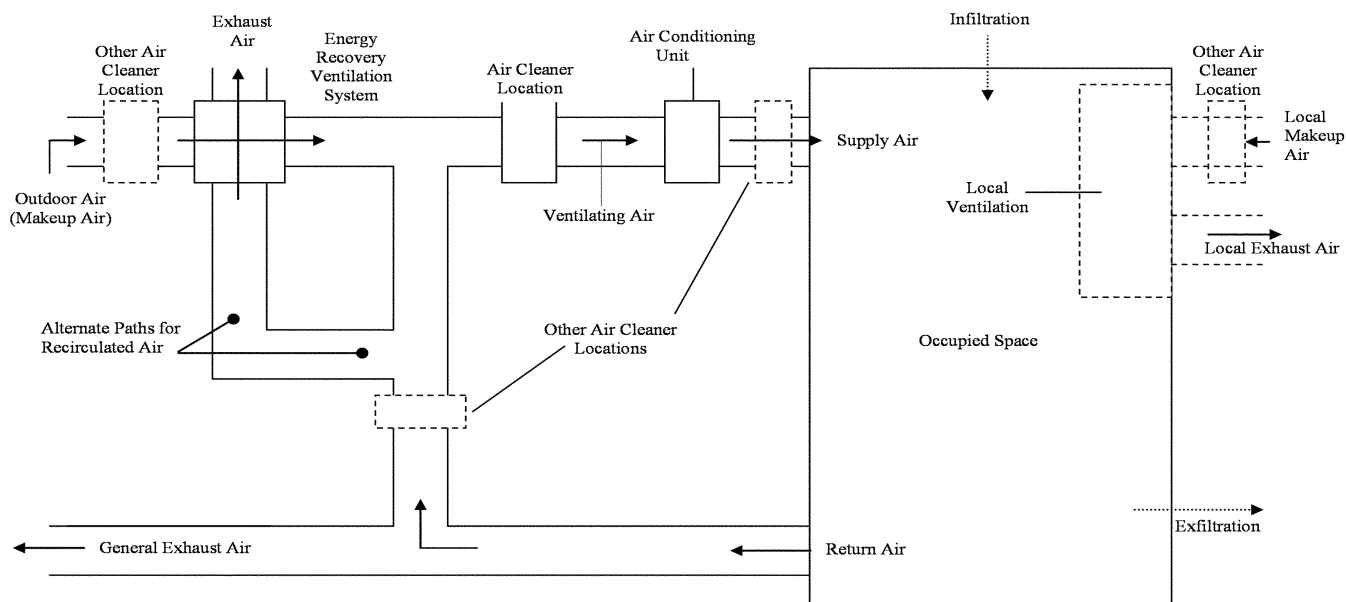

Figure 3.1 Ventilation system.

organization that is recognized as authoritative and has the scope and expertise to establish guidelines, limit values, or concentrations levels for airborne contaminants.

**concentration:** the quantity of one constituent dispersed in a defined amount of another.

**conditioned space:** that part of a building that is heated or cooled, or both, for the comfort of occupants.

**contaminant:** an unwanted airborne constituent that may reduce acceptability of the air.

**demand-controlled ventilation (DCV):** any means by which the breathing zone outdoor airflow ( $V_{bz}$ ) can be varied to the occupied space or spaces based on the actual or estimated number of occupants and/or ventilation requirements of the occupied zone.

**energy recovery ventilation system:** a device or combination of devices applied to provide the outdoor air for ventilation in which energy is transferred between the intake and exhaust airstreams.

**environmental tobacco smoke (ETS):** the “aged” and diluted combination of both side-stream smoke (smoke from the lit end of a cigarette or other tobacco product) and exhaled mainstream smoke (smoke that is exhaled by a smoker). ETS is commonly referred to as *secondhand smoke*.

**ETS-free area:** an area where no smoking occurs and that is separated from ETS areas according to the requirements of this standard.

**Note:** A no-smoking area is not necessarily an ETS-free area.

**ETS area:** spaces where smoking is permitted, as well as those not separated from spaces where smoking is permitted in accord with the requirements of Section 5 in this standard.

**exfiltration:** uncontrolled outward air leakage from conditioned spaces through unintentional openings in ceilings, floors, and walls to unconditioned spaces or the outdoors caused by pressure differences across these openings due to wind, inside-outside temperature differences (stack effect), and imbalances between supply and exhaust airflow rates.

**industrial space:** an indoor environment where the primary activity is production or manufacturing processes. The processes in these spaces may generate contaminants with characteristics and in quantities dictating that principles of worker safety and industrial hygiene be used to define contaminant control strategies, including ventilation. Also, the primary occupants of these spaces consist of the individuals involved in these processes.

**infiltration:** uncontrolled inward air leakage to conditioned spaces through unintentional openings in ceilings, floors, and walls from unconditioned spaces or the outdoors caused by the same pressure differences that induce exfiltration.

**mechanical ventilation:** ventilation provided by mechanically powered equipment, such as motor-driven fans and blowers, but not by devices such as wind-driven turbine ventilators and mechanically operated windows.

**microorganism:** a microscopic organism, especially a bacterium, fungus, or protozoan.

**natural ventilation:** ventilation provided by thermal, wind, or diffusion effects through doors, windows, or other intentional openings in the building.

**net occupiable area:** the floor area of an occupiable space defined by the inside surfaces of its walls but excluding shafts, column enclosures, and other permanently enclosed, inaccessible, and unoccupiable areas. Obstructions in the space such as furnishings, display or storage racks, and other obstructions,

whether temporary or permanent, are considered to be part of the net occupiable area.

**occupiable space:** an enclosed space intended for human activities, excluding those spaces that are intended primarily for other purposes, such as storage rooms and equipment rooms, and that are only occupied occasionally and for short periods of time.

**odor:** a quality of gases, liquids, or particles that stimulates the olfactory organ.

**readily accessible:** capable of being reached quickly for operation without requiring those for whom ready access is required to climb over or remove obstacles or to resort to portable ladders, chairs, or other climbing aids.

**ventilation:** the process of supplying air to or removing air from a space for the purpose of controlling air contaminant levels, humidity, or temperature within the space.

**volume, space:** the total volume of an occupiable space enclosed by the building envelope, plus that of any spaces permanently open to the occupiable space, such as a ceiling attic used as a ceiling return plenum.

**ventilation zone:** any indoor area that requires ventilation and consists of one or more occupiable spaces with similar occupancy category (see Table 6-1), occupant density, zone air distribution effectiveness (see Section 6.2.2.2), and zone primary airflow (see Section 6.2.5.1) per unit area.

**Note:** A ventilation zone is not necessarily an independent thermal control zone; however, spaces that can be combined for load calculation purposes can often be combined into a single zone for ventilation calculations purposes.

## 4. OUTDOOR AIR QUALITY

Outdoor air quality shall be investigated in accordance with Sections 4.1 and 4.2 prior to completion of ventilation system design. The results of this investigation shall be documented in accordance with Section 4.3.

**4.1 Regional Air Quality.** The status of compliance with national ambient air quality standards shall be determined for the geographic area of the building site.

**4.1.1** In the United States, compliance status shall be either in "attainment" or "non-attainment" with the *National Ambient Air Quality Standards* (NAAQS)<sup>1</sup>. In the United States, areas with no EPA compliance status designation shall be considered "attainment" areas.

**Note:** The *National Ambient Air Quality Standards* (NAAQS) are shown in Informative Appendix I, Table I-1.

**4.2 Local Air Quality.** An observational survey of the building site and its immediate surroundings shall be conducted during hours the building is expected to be normally occupied to identify local contaminants from surrounding facilities that may be of concern if allowed to enter the building.

**4.3 Documentation.** Documentation of the outdoor air quality investigation shall be reviewed with building owners or their representative and shall include the following as a minimum:

- a. Regional air quality compliance status.  
**Note:** Regional outdoor air quality compliance status for the United States is available from the U.S. Environmental Protection Agency located under [www.epa.gov](http://www.epa.gov).
- b. Local survey information:
  1. Date of observations
  2. Time of observations
  3. Site description
  4. Description of facilities on site and on adjoining properties
  5. Observation of odors or irritants
  6. Observation of visible plumes or visible air contaminants
  7. Description of sources of vehicle exhaust on site and on adjoining properties
  8. Identification of potential contaminant sources on the site and from adjoining properties
- c. Conclusions regarding the acceptability of outdoor air quality based on consideration of information from investigation.

## 5. SYSTEMS AND EQUIPMENT

**5.1 Ventilation Air Distribution.** Ventilating systems shall be designed in accordance with the following requirements.

**5.1.1 Designing for Air Balancing.** The ventilation air distribution system shall be provided with means to adjust the system to achieve at least the minimum ventilation airflow as required by Section 6 under any load condition.

**5.1.2 Plenum Systems.** When the ceiling or floor plenum is used both to recirculate return air and to distribute ventilation air to ceiling-mounted or floor-mounted terminal units, the system shall be engineered such that each space is provided with its required minimum ventilation airflow.

**Note:** Systems with direct connection of ventilation air ducts to terminal units, for example, comply with this requirement.

**5.1.3 Documentation.** The design documents shall specify minimum requirements for air balance testing or reference applicable national standards for measuring and balancing airflow. The design documentation shall state assumptions that were made in the design with respect to ventilation rates and air distribution.

**5.2 Exhaust Duct Location.** Exhaust ducts that convey potentially harmful contaminants shall be negatively pressurized relative to spaces through which they pass, so that exhaust air cannot leak into occupied spaces; supply, return, or outdoor air ducts; or plenums.

**Exception:** Exhaust ducts that are sealed in accordance with SMACNA Seal Class A.<sup>2</sup>

**5.3 Ventilation System Controls.** Mechanical ventilation systems shall include controls, manual or automatic, that enable the fan system to operate whenever the spaces served are occupied. The system shall be designed to maintain no less than the minimum outdoor airflow as required by Section 6 under any load condition.

**Note:** Variable Air Volume (VAV) systems with fixed outdoor air damper positions must comply with this requirement at minimum system primary airflow.

**5.4 Airstream Surfaces.** All airstream surfaces in equipment and ducts in the heating, ventilating, and air-conditioning system shall be designed and constructed in accordance with the following requirements.

**5.4.1 Resistance to Mold Growth.** Material surfaces shall be determined to be resistant to mold growth in accordance with a standardized test method, such as the “Mold Growth and Humidity Test” in UL 181,<sup>3</sup> ASTM C 1338,<sup>4</sup> or comparable test methods.

**Exception:** Sheet metal surfaces and metal fasteners.

**Note:** Even with this resistance, any airstream surface that is continuously wetted is still subject to microbial growth.

**5.4.2 Resistance to Erosion.** Airstream surface materials shall be evaluated in accordance with the “Erosion Test” in UL 181<sup>3</sup> and shall not break away, crack, peel, flake off, or show evidence of delamination or continued erosion under test conditions.

**Exception:** Sheet metal surfaces and metal fasteners.

**5.5 Outdoor Air Intakes.** Ventilation system outdoor intakes shall be designed in accordance with the following.

**5.5.1 Location.** Outdoor air intakes (including openings that are required as part of a natural ventilation system) shall be located such that the shortest distance from the intake to any specific potential outdoor contaminant source shall be equal to or greater than the separation distance listed in Table 5-1.

**Exception:** Other minimum separation distances shall be permitted, provided it can be shown analytically that an

equivalent or lesser rate of introduction of contaminants from outdoor sources will be attained.

**Note:** Appendix F presents an analytical method for determining the minimum separation distances based on dilution of outdoor contaminants.

**5.5.2 Rain Entrainment.** Outdoor air intakes that are part of the mechanical ventilation system shall be designed to manage rain entrainment in accordance with any one of the following:

- a. Limit water penetration through the intake to 0.07 oz/ft<sup>2</sup>·h (21.5 g/m<sup>2</sup>·h) of inlet area when tested using the rain test apparatus described in Section 58 of UL 1995.<sup>12</sup>
- b. Select louvers that limit water penetration to a maximum of 0.01 oz/ft<sup>2</sup> (3 g/m<sup>2</sup>) of louver free area at the maximum intake velocity. This water penetration rate shall be determined for a minimum 15-minute test duration when subjected to a water flow rate of 0.25 gal/min (16 mL/s) as described under the Water Penetration Test in AMCA 500-L<sup>13</sup> or equivalent. Manage the water that penetrates the louver by providing a drainage area and/or moisture removal devices.
- c. Select louvers that restrict wind-driven rain penetration to less than 2.36 oz/ft<sup>2</sup>·h (721 g/m<sup>2</sup>·h) when subjected to a simulated rainfall of 3 in. (75 mm) per hour and a 29 mph (13 m/s) wind velocity at the design outdoor air intake rate with the air velocity calculated based on the louver face area.

**Note:** This performance corresponds to Class A (99% effectiveness) when rated according to AMCA 511<sup>14</sup> and tested per AMCA 500-L.<sup>13</sup>

**TABLE 5-1 Air Intake Minimum Separation Distance**

Object	Minimum Distance, ft (m)
Class 2 air exhaust/relief outlet (Note 1)	10 (3)
Class 3 air exhaust/relief outlet (Note 1)	15 (5)
Class 4 air exhaust/relief outlet (Note 2)	30 (10)
Plumbing vents terminating less than 3 ft (1 m) above the level of the outdoor air intake	10 (3)
Plumbing vents terminating at least 3 ft (1 m) above the level of the outdoor air intake	3 (1)
Vents, chimneys, and flues from combustion appliances and equipment (Note 3)	15 (5)
Garage entry, automobile loading area, or drive-in queue (Note 4)	15 (5)
Truck loading area or dock, bus parking/idling area (Note 4)	25 (7.5)
Driveway, street, or parking place (Note 4)	5 (1.5)
Thoroughfare with high traffic volume	25 (7.5)
Roof, landscaped grade, or other surface directly below intake (Notes 5 and 6)	1 (0.30)
Garbage storage/pick-up area, dumpsters	15 (5)
Cooling tower intake or basin	15 (5)
Cooling tower exhaust	25 (7.5)

Note 1: This requirements applies to the distance from the outdoor air intakes for one ventilation system to the exhaust/relief outlets for any other ventilation system.  
 Note 2: Minimum distance listed does not apply to laboratory fume hood exhaust air outlets. Separation criteria for fume hood exhaust shall be in compliance with NFPA 45<sup>5</sup> and ANS/AIHA Z9.5.<sup>6</sup> Information on separation criteria for industrial environments can be found in the *ACGIH Industrial Ventilation Manual*<sup>7</sup> and in the *ASHRAE Handbook—HVAC Applications*.<sup>8</sup>  
 Note 3: Shorter separation distances shall be permitted when determined in accordance with (a) ANSI Z223.1/NFPA 54<sup>9</sup> for fuel gas burning appliances and equipment, (b) NFPA 31<sup>10</sup> for oil burning appliances and equipment, or (c) NFPA 211<sup>11</sup> for other combustion appliances and equipment.  
 Note 4: Distance measured to closest place that vehicle exhaust is likely to be located.  
 Note 5: Shorter separation distance shall be permitted where outdoor surfaces are sloped more than 45 degrees from horizontal or that are less than 1 in. (3 cm) wide.  
 Note 6: Where snow accumulation is expected, the surface of the snow at the expected average snow depth constitutes the “other surface directly below intake.”



- d. Use rain hoods sized for no more than 500 fpm (2.5 m/s) face velocity with a downward-facing intake such that all intake air passes upward through a horizontal plane that intersects the solid surfaces of the hood before entering the system.
- e. Manage the water that penetrates the intake opening by providing a drainage area and/or moisture removal devices.

**5.5.3 Rain Intrusion.** Air-handling and distribution equipment mounted outdoors shall be designed to prevent rain intrusion into the airstream when tested at design airflow and with no airflow, using the rain test apparatus described in Section 58 of UL 1995.<sup>12</sup>

**5.5.4 Snow Entrainment.** Where climate dictates, outdoor air intakes that are part of the mechanical ventilation system shall be designed to manage water from snow, which is blown or drawn into the system, as follows:

- a. Suitable access doors to permit cleaning of wetted surfaces shall be provided.
- b. Outdoor air ductwork or plenums shall pitch to drains designed in accordance with the requirements of Section 5.10.

**5.5.5 Bird Screens.** Outdoor air intakes shall include a screening device designed to prevent penetration by a 0.5 in. (13 mm) diameter probe. The screening device material shall be corrosion resistant. The screening device shall be located, or other measures shall be taken, to prevent bird nesting within the outdoor air intake.

*Note:* Any horizontal surface may be subject to bird nesting.

**5.6 Local Capture of Contaminants.** The discharge from noncombustion equipment that captures the contaminants generated by the equipment shall be ducted directly to the outdoors.

**Exception:** Equipment specifically designed for discharge indoors in accordance with the manufacturer's recommendations.

**5.7 Combustion Air.** Fuel-burning appliances, both vented and unvented, shall be provided with sufficient air for combustion and adequate removal of combustion products in accordance with manufacturer instructions. Products of combustion from vented appliances shall be vented directly outdoors.

**5.8 Particulate Matter Removal.** Particulate matter filters or air cleaners having a minimum efficiency reporting value (MERV) of not less than 6 when rated in accordance with ANSI/ASHRAE Standard 52.2<sup>15</sup> shall be provided upstream of all cooling coils or other devices with wetted surfaces through which air is supplied to an occupiable space.

**5.9 Dehumidification Systems.** Mechanical air-conditioning systems with dehumidification capability shall be designed to comply with the following.

**5.9.1 Relative Humidity.** Occupied space relative humidity shall be limited to 65% or less when system performance

is analyzed with outdoor air at the dehumidification design condition (that is, design dew point and mean coincident dry-bulb temperatures) and with the space interior loads (both sensible and latent) at cooling design values and space solar loads at zero.

*Note:* System configuration and/or climatic conditions may adequately limit space relative humidity at these conditions without additional humidity-control devices. The specified conditions challenge the system dehumidification performance with high outdoor latent load and low space sensible heat ratio.

**Exception:** Spaces where process or occupancy requirements dictate higher humidity conditions, such as kitchens, hot tub rooms that contain heated standing water, refrigerated or frozen storage rooms and ice rinks, and/or spaces designed and constructed to manage moisture, such as shower rooms, pools, and spas.

**5.9.2 Exfiltration.** For a building, the ventilation system(s) shall be designed to ensure that the minimum outdoor air intake exceeds the maximum exhaust airflow whenever the mechanical air-conditioning systems are dehumidifying.

**Exception:** Where excess exhaust is required by process considerations and approved by the authority having jurisdiction, such as in certain industrial facilities.

*Note:* Although individual zones within a building may be neutral or negative with respect to outdoors or to other zones, net positive mechanical intake airflow for the building as a whole reduces infiltration of untreated outdoor air.

**5.10 Drain Pans.** Drain pans, including their outlets and seals, shall be designed and constructed in accordance with this section.

**5.10.1 Drain Pan Slope.** Pans intended to collect and drain liquid water shall be sloped at least 0.125 in. per foot (10 mm per meter) from the horizontal toward the drain outlet or shall be otherwise designed to ensure that water drains freely from the pan whether the fan is ON or OFF.

**5.10.2 Drain Outlet.** The drain pan outlet shall be located at the lowest point(s) of the drain pan and shall be of sufficient diameter to preclude drain pan overflow under any normally expected operating condition.

**5.10.3 Drain Seal.** For configurations that result in negative static pressure at the drain pan relative to the drain outlet (such as a draw-through unit), the drain line shall include a P-trap or other sealing device designed to maintain a seal against ingestion of ambient air while allowing complete drainage of the drain pan under any normally expected operating condition, whether the fan is ON or OFF.

**5.10.4 Pan Size.** The drain pan shall be located under the water-producing device. Drain pan width shall be sufficient to collect water droplets across the entire width of the water-producing device or assembly. For horizontal airflow configurations, the drain pan length shall begin at the leading face or edge of the water-producing device or assembly and extend downstream from the leaving face or edge to a distance of either:

- a. one half of the installed vertical dimension of the water-producing device or assembly, or
- b. as necessary to limit water droplet carryover beyond the drain pan to 0.0044 oz per ft<sup>2</sup> (1.5 mL per m<sup>2</sup>) of face area per hour under peak sensible and peak dew point design conditions, considering both latent load and coil face velocity.

## 5.11 Finned-Tube Coils and Heat Exchangers

**5.11.1 Drain Pans.** A drain pan in accordance with Section 5.10 shall be provided beneath all dehumidifying cooling coil assemblies and all condensate-producing heat exchangers.

**5.11.2 Finned-Tube Coil Selection for Cleaning.** Individual finned-tube coils or multiple finned-tube coils in series without intervening access space(s) of at least 18 in. (457 mm) shall be selected to result in no more than 0.75 in. w.c. (187 Pa) combined dry coil pressure drop at 500 fpm (2.54 m/s) face velocity.

**Exception:** When access for cleaning of both upstream and downstream coil surfaces is provided as well as clear and complete instructions for access and cleaning of both upstream and downstream coil surfaces are provided.

**5.12 Humidifiers and Water-Spray Systems.** Steam and direct evaporation humidifiers, air washers, and other water-spray systems shall be designed in accordance with this section.

**5.12.1 Water Quality.** Water shall originate directly from a potable source or from a source with equal or better water quality.

**5.12.2 Obstructions.** Air cleaners or ductwork obstructions, such as turning vanes, volume dampers, and duct offsets greater than 15 degrees, that are installed downstream of humidifiers or water spray systems shall be located a distance equal to or greater than the absorption distance recommended by the humidifier or water spray system manufacturer.

**Exception:** Equipment such as eliminators, coils, or evaporative media shall be permitted to be located within the absorption distance recommended by the manufacturer, provided a drain pan complying with the requirements of Section 5.10 is used to capture and remove any water that may drop out of the airstream due to impingement on these obstructions.

## 5.13 Access for Inspection, Cleaning, and Maintenance

**5.13.1 Equipment Clearance.** Ventilation equipment shall be installed with sufficient working space for inspection and routine maintenance (e.g., filter replacement and fan belt adjustment and replacement).

**5.13.2 Ventilation Equipment Access.** Access doors, panels, or other means shall be provided and sized to allow convenient and unobstructed access sufficient to inspect, maintain, and calibrate all ventilation system components for which routine inspection, maintenance, or calibration is necessary. Ventilation system components comprise, for exam-

ple, air-handling units, fan-coil units, water-source heat pumps, other terminal units, controllers, and sensors.

**5.13.3 Air Distribution System.** Access doors, panels, or other means shall be provided in ventilation equipment, ductwork, and plenums, located and sized to allow convenient and unobstructed access for inspection, cleaning, and routine maintenance of the following:

- a. Outdoor air intake areaways or plenums
- b. Mixed air plenums
- c. Upstream surface of each heating, cooling, and heat-recovery coil or coil assembly having a total of four rows or less
- d. Both upstream and downstream surface of each heating, cooling, and heat-recovery coil having a total of more than four rows and air washers, evaporative coolers, heat wheels, and other heat exchangers
- e. Air cleaners
- f. Drain pans and drain seals
- g. Fans
- h. Humidifiers

**5.14 Building Envelope and Interior Surfaces.** The building envelope and interior surfaces within the building envelope shall be designed in accordance with the following.

**5.14.1 Building Envelope.** The building envelope, including roofs, walls, fenestration systems, and foundations, shall comply with the following:

- a. A weather barrier or other means shall be provided to prevent liquid water penetration into the envelope.

**Exception:** When the envelope is engineered to allow incidental water penetration to occur without resulting in damage to the envelope construction.

- b. An appropriately placed vapor retarder or other means shall be provided to limit water vapor diffusion to prevent condensation on cold surfaces within the envelope.

**Exception:** When the envelope is engineered to manage incidental condensation without resulting in damage to the envelope construction.

- c. Exterior joints, seams, or penetrations in the building envelope that are pathways for air leakage shall be caulked, gasketed, weather-stripped, provided with continuous air barrier, or otherwise sealed to limit infiltration through the envelope to reduce uncontrolled entry of outdoor air moisture and pollutants.

**Note:** In localities where soils contain high concentrations of radon or other soil gas contaminants, the authority having jurisdiction may impose additional measures, such as sub-slab depressurization.

**5.14.2 Condensation on Interior Surfaces.** Pipes, ducts, and other surfaces within the building whose surface temperatures are expected to fall below the surrounding dew-point temperature shall be insulated. The insulation system thermal resistance and material characteristics shall be sufficient to

prevent condensation from forming on the exposed surface and within the insulating material.

**Exceptions:**

- a. Where condensate will wet only surfaces that can be managed to prevent or control mold growth.
- b. Where local practice has demonstrated that condensation does not result in mold growth.

**5.15 Buildings with Attached Parking Garages.** In order to limit the entry of vehicular exhaust into occupiable spaces, buildings with attached parking garages shall be designed to:

- a. maintain the garage pressure at or below the pressure of the adjacent occupiable spaces, or
- b. use a vestibule to provide an airlock between the garage and the adjacent occupiable spaces, or
- c. otherwise limit migration of air from the attached parking garage into the adjacent occupiable spaces of the building in a manner acceptable to the authority having jurisdiction.

**5.16 Air Classification and Recirculation.** Air shall be classified, and its recirculation shall be limited in accordance with the following sections.

**5.16.1 Classification.** Air (return, transfer, or exhaust air) leaving each space or location shall be designated at an expected air-quality classification not less than that shown in Table 5-2, Table 6-1, or Table 6-4 or as approved by the authority having jurisdiction. Air leaving spaces or locations that are not listed in Table 5-2, Table 6-1, or Table 6-4 shall be designated with the same classification as air from the most similar space or location listed in terms of occupant activities and building construction.

**Exception:** Air from spaces where ETS is present. (Classification of air from spaces where ETS is present is not addressed. Spaces that are expected to include ETS do not have a classification listed in Table 6-1.)

**Note:** Classifications in Table 5-2, Table 6-1, and Table 6-4 are based on relative contaminant concentration using the following subjective criteria:

- Class 1: Air with low contaminant concentration, low sensory-irritation intensity, and inoffensive odor.
- Class 2: Air with moderate contaminant concentration, mild sensory-irritation intensity, or mildly offensive odors. Class 2 air also includes air that is not necessarily harmful or objectionable but that is inappropriate for transfer or recirculation to spaces used for different purposes.
- Class 3: Air with significant contaminant concentration, significant sensory-irritation intensity, or offensive odor.
- Class 4: Air with highly objectionable fumes or gases or with potentially dangerous particles, bioaerosols, or gases, at concentrations high enough to be considered harmful.

**5.16.2 Redesignation**

**5.16.2.1 Air Cleaning.** If air leaving a space or location passes through an air-cleaning system, redesignation of the

**TABLE 5-2 Airstreams**

Description	Air Class
Diazo printing equipment discharge	4
Commercial kitchen grease hoods	4
Commercial kitchen hoods other than grease	3
Laboratory hoods	4
Residential kitchen vented hoods	3
Hydraulic elevator machine room	2

cleaned air to a cleaner classification shall be permitted, using the subjective criteria noted above, with the approval of the authority having jurisdiction.

**5.16.2.2 Transfer.** A mixture of air that has been transferred through or returned from spaces or locations with different air classes shall be redesignated with the highest classification among the air classes mixed.

**Note:** For example, mixed return air to a common system serving both a Class 1 space and a Class 2 space is designated as Class 2 air.

**5.16.2.3 Ancillary Spaces.** Redesignation of Class 1 air to Class 2 air shall be permitted for Class 1 “spaces that are ancillary to Class 2 spaces.”

**Note:** For example, an office within a restaurant may be designated as a space ancillary to a Class 2 space thus enabling the office to receive Class 2 air.

**5.16.3 Recirculation Limitations.** When the Ventilation Rate Procedure of Section 6 is used to determine ventilation air-flow values, recirculation of air shall be limited in accordance with the requirements of this section.

**5.16.3.1 Class 1 Air.** Recirculation or transfer of Class 1 air to any space shall be permitted.

**5.16.3.2 Class 2 Air**

**5.16.3.2.1** Recirculation of Class 2 air within the space of origin shall be permitted.

**5.16.3.2.2** Recirculation or transfer of Class 2 air to other Class 2 or Class 3 spaces shall be permitted, provided the other spaces are used for the same or similar purpose or task and involve the same or similar pollutant sources as the Class 2 space.

**5.16.3.2.3** Transfer of Class 2 air to toilet rooms shall be permitted.

**5.16.3.2.4** Recirculation or transfer of Class 2 air to Class 4 spaces shall be permitted.

**5.16.3.2.5** Class 2 air shall be recirculated or transferred to Class 1 spaces.

**Exception:** When using any energy recover device, recirculation from leakage, carryover, or transfer from the exhaust side of the energy recovery device is permitted. Recirculated Class 2 air shall not exceed 10% of the outdoor air intake flow.

**5.16.3.3 Class 3 Air**

**5.16.3.3.1** Recirculation of Class 3 air within the space of original shall be permitted.

**5.16.3.3.2** Class 3 air shall not be recirculated or transferred to any other space.

**Exception:** When using any energy recover device, recirculation from leakage, carryover, or transfer from the exhaust side of the energy recovery device is permitted. Recirculated Class 3 air shall not exceed 5% of the outdoor air intake flow.

**5.16.3.4 Class 4 Air.** Class 4 air shall not be recirculated or transferred to any space nor recirculated within the space of origin.

**5.16.4 Documentation.** Design documentation shall indicate the justification for classification of air from any occupancy category, airstream, or location not listed in Table 5-2, Table 6-1, or Table 6-4.

**5.17 Requirements for Buildings Containing ETS Areas and ETS-Free Areas.** The requirements of this section must be met when a building contains both ETS areas and ETS-free areas. Such buildings shall be constructed and operated in accordance with Sections 5.17.1 through 5.17.8. This section does not purport to achieve acceptable indoor air quality in ETS areas.

**5.17.1 Classification.** All spaces shall be classified as either ETS-free areas or ETS areas.

**5.17.2 Pressurization.** ETS-free areas shall be at a positive pressure with respect to any adjacent or connected ETS areas.

**Note:** Examples of methods for demonstrating relative pressure include engineering analysis, pressure differential measurement, and airflow measurement.

**Exceptions:**

- a. Dwelling units, including hotel and motel guest rooms, and adjacent properties under different ownership with separation walls that are structurally independent and that contain no openings. This exception shall apply only when:
  1. the separation walls are constructed as smoke barriers in accordance with the requirements of applicable standards;
  2. the separation walls include an air barrier consisting of a continuous membrane or surface treatment in the separation wall that has documented resistance to air leakage; continuity of the barrier shall be maintained at openings for pipes, ducts, and other conduits and at points where the barrier meets the outside walls and other barriers; and
  3. interior corridors common to ETS and ETS-free areas are mechanically supplied with outdoor air at the rate of 0.1 cfm/ft<sup>2</sup> (0.5 L/s·m<sup>2</sup>).
- b. Adjacent spaces otherwise required to be held at negative pressure and posted with signs due to the presence of hazardous or flammable materials or vapors.

**5.17.3 Separation.** Solid walls, floors, ceilings, and doors equipped with automatic closing mechanisms shall separate ETS areas from ETS-free areas.

**Exception:** Openings without doors are permitted in the separation where engineered systems are designed to

provide airflow from ETS-free areas into ETS areas, notwithstanding eddies that may occur in the immediate vicinity of the boundary between the ETS and ETS-free areas and reverse flow that may occur due to short-term conditions such as wind gusts.

**Note:** Examples of methods for demonstrating air motion are engineering analysis and the use of a directional airflow indicator at representative locations in the opening, such as on 1 ft (0.3 m) centers or at locations required for duct traverses in standard testing and balancing procedures, such as those described in ASHRAE Standard 111.<sup>16</sup>

**5.17.4 Transfer Air.** When air is transferred from ETS-free areas to ETS areas, the transfer airflow rate shall be maintained regardless of whether operable doors or windows between ETS-free and ETS areas are opened or closed. Acceptable means of doing so include fixed openings in doors, walls, or floors, transfer grilles, transfer ducts, or unducted air plenums with air pressure differentials in compliance with Section 5.17.2.

**5.17.5 Recirculation.** Air-handling and natural ventilation systems shall not recirculate or transfer air from an ETS area to an ETS-free area.

**5.17.6 Exhaust Systems.** Exhaust or relief air from an ETS area shall be discharged such that none of the air is recirculated back into any ETS-free area.

**5.17.7 Signage.** A sign shall be posted outside each entrance to each ETS area. The sign shall state, as a minimum, "This Area May Contain Environmental Tobacco Smoke" in letters at least 1 in. (25 mm) high or otherwise in compliance with accessibility guidelines.

**Note:** Based on the definition of ETS area, such a sign may be posted outside a larger ETS area that includes the area where smoking is permitted.

**Exception:** Instead of the specified sign, equivalent notification means acceptable to the authority having jurisdiction may be used.

**5.17.8 Reclassification.** An area that was previously an ETS area, but now meets the requirements of an ETS-free area, may be classified as such after intentional or allowed smoke exposure has stopped and odor and irritation from residual ETS contaminants are not apparent.

## 6. PROCEDURES

**6.1 General.** The Ventilation Rate Procedure, the IAQ Procedure, and/or the Natural Ventilation Procedure shall be used to meet the requirements of this section. In addition, the requirements for exhaust ventilation in Section 6.5 shall be met regardless of the method used to determine minimum outdoor airflow rates.

**Note:** Although the intake airflow determined using each of these approaches may differ significantly because of assumptions about the design, any of these approaches is a valid basis for design.

**6.1.1 Ventilation Rate Procedure.** The prescriptive design procedure presented in Section 6.2, in which outdoor air intake rates are determined based on space type/application, occupancy

level, and floor area, shall be permitted to be used for any zone or system.

**Note:** The Ventilation Rate Procedure minimum rates are based on contaminant sources and source strengths that are typical for the listed occupancy categories.

**6.1.2 IAQ Procedure.** This performance-based design procedure (presented in Section 6.3), in which the building outdoor air intake rates and other system design parameters are based on an analysis of contaminant sources, contaminant concentration limits, and level of perceived indoor air acceptability, shall be permitted to be used for any zone or system.

**6.1.3 Natural Ventilation Procedure.** The prescriptive design procedure presented in Section 6.4, in which outdoor air is provided through openings to the outdoors, shall be permitted to be used for any zone or portion of a zone in conjunction with mechanical ventilation systems as required in Section 6.4.

**6.2 Ventilation Rate Procedure.** The outdoor air intake flow ( $V_{oi}$ ) for a ventilation system shall be determined in accordance with Sections 6.2.1 through 6.2.7.

**Note:** Additional explanation of terms used below is contained in Appendix A, along with a ventilation system schematic (Figure A-1).

**6.2.1 Outdoor Air Treatment.** If outdoor air is judged to be unacceptable in accordance with Section 4.1, each ventilation system that provides outdoor air through a supply fan shall comply with the following sections.

**Exception:** Systems supplying air for enclosed parking garages, warehouses, storage rooms, janitor's closets, trash rooms, recycling areas, shipping/receiving/distribution areas.

**Note:** Occupied spaces ventilated with outdoor air that is judged to be unacceptable are subject to reduced air quality when outdoor air is not cleaned prior to introduction to the occupied spaces.

**6.2.1.1 Particulate Matter Smaller than 10 Micrometers (PM10).** When the building is located in an area where the national standard or guideline for PM10<sup>1</sup> is exceeded, particle filters or air-cleaning devices shall be provided to clean the outdoor air at any location prior to its introduction to occupied spaces. Particulate matter filters or air cleaners shall have a Minimum Efficiency Reporting Value (MERV) of 6 or higher when rated in accordance with ANSI/ASHRAE Standard 52.2.<sup>15</sup>

**Note:** See Appendix E for resources regarding selected PM10 national standards and guidelines.

**6.2.1.2 Particulate Matter smaller than 2.5 micrometers (PM2.5).** When the building is located in an area where the national standard or guideline for PM2.5<sup>1</sup> is exceeded, particle filters or air cleaning devices shall be provided to clean the outdoor air at any location prior to its introduction to occupied spaces. Particulate matter filters or air cleaners shall have a Minimum Efficiency Reporting Value (MERV) of 11 or higher when rated in accordance with ASHRAE Standard 52.2.<sup>15</sup>

**Note:** See Appendix E for resources regarding selected PM2.5 national standards and guidelines.

**6.2.1.3 Ozone.** Air-cleaning devices for ozone shall be provided when the most recent three-year average annual fourth-highest daily maximum eight-hour average ozone concentration exceeds 0.107 ppm (209  $\mu\text{g}/\text{m}^3$ ).

**Note:** See Appendix E for a list of United States locations exceeding the most recent 3-year average annual fourth-highest daily maximum 8-hour average ozone concentration of 0.107 ppm.

Such air-cleaning devices shall have a minimum volumetric ozone removal efficiency of 40% when installed, operated, and maintained in accordance with manufacturer recommendations and shall be approved by the authority having jurisdiction. Such devices shall be operated whenever outdoor ozone levels are expected to exceed 0.107 ppm (209  $\mu\text{g}/\text{m}^3$ ).

**Exceptions:** Air cleaning for ozone is not required when:

- The minimum system design outdoor air intake flow results in 1.5 ach or less.
- Controls are provided that sense outdoor ozone level and reduce intake airflow to result in 1.5 ach or less while complying with the outdoor airflow requirements of Section 6.
- Outdoor air is brought into the building and heated by direct-fired, makeup air units.

**6.2.1.4 Other Outdoor Contaminants.** When the building is located in an area where the national standard for one or more contaminants not specifically addressed in Section 6.2.1 is exceeded, any design assumptions and/or calculations related to the impact on indoor air quality shall be included in the design documents.

**6.2.2 Zone Calculations.** *Ventilation zone* parameters shall be determined in accordance with Sections 6.2.2.1 through 6.2.2.3 for each *ventilation zone* served by the ventilation system.

**6.2.2.1 Breathing Zone Outdoor Airflow.** The outdoor airflow required in the breathing zone of the occupiable space or spaces in a *ventilation zone*, i.e., the breathing zone outdoor airflow ( $V_{bz}$ ), shall be no less than the value determined in accordance with Equation 6-1.

$$V_{bz} = R_p \cdot P_z + R_a \cdot A_z \quad (6-1)$$

where

$A_z$  = zone floor area: the net occupiable floor area of the *ventilation zone* ft<sup>2</sup> (m<sup>2</sup>)

$P_z$  = zone population: the number of people in the *ventilation zone* during typical usage.

$R_p$  = outdoor airflow rate required per person as determined from Table 6-1

**Note:** These values are based on adapted occupants.

$R_a$  = outdoor airflow rate required per unit area as determined from Table 6-1

**Note:** Equation 6-1 accounts for people-related sources and area-related sources independently in the determination of the outdoor air rate required at the *breathing zone*. The use of Equation 6-1 in the context of this standard does not necessarily imply that simple addition of outdoor airflow rates for

**TABLE 6-1 MINIMUM VENTILATION RATES IN BREATHING ZONE**  
**(This table is not valid in isolation; it must be used in conjunction with the accompanying notes.)**

Occupancy Category	People Outdoor Air Rate		Area Outdoor Air Rate		Notes	Default Values		Air Class	
	$R_p$		$R_a$			Occupant Density (see Note 4)	Combined Outdoor Air Rate (see Note 5)		
	cfm/person	L/s-person	cfm/ft <sup>2</sup>	L/s·m <sup>2</sup>			#/1000 ft <sup>2</sup> or #/100 m <sup>2</sup>		cfm/person
<b>Correctional Facilities</b>									
Cell	5	2.5	0.12	0.6		25	10	4.9	2
Dayroom	5	2.5	0.06	0.3		30	7	3.5	1
Guard stations	5	2.5	0.06	0.3		15	9	4.5	1
Booking/waiting	7.5	3.8	0.06	0.3		50	9	4.4	2
<b>Educational Facilities</b>									
Daycare (through age 4)	10	5	0.18	0.9		25	17	8.6	2
Daycare sickroom	10	5	0.18	0.9		25	17	8.6	3
Classrooms (ages 5–8)	10	5	0.12	0.6		25	15	7.4	1
Classrooms (age 9 plus)	10	5	0.12	0.6		35	13	6.7	1
Lecture classroom	7.5	3.8	0.06	0.3		65	8	4.3	1
Lecture hall (fixed seats)	7.5	3.8	0.06	0.3		150	8	4.0	1
Art classroom	10	5	0.18	0.9		20	19	9.5	2
Science laboratories	10	5	0.18	0.9		25	17	8.6	2
University/college laboratories	10	5	0.18	0.9		25	17	8.6	2
Wood/metal shop	10	5	0.18	0.9		20	19	9.5	2
Computer lab	10	5	0.12	0.6		25	15	7.4	1
Media center	10	5	0.12	0.6	A	25	15	7.4	1
Music/theater/dance	10	5	0.06	0.3		35	12	5.9	1
Multi-use assembly	7.5	3.8	0.06	0.3		100	8	4.1	1
<b>Food and Beverage Service</b>									
Restaurant dining rooms	7.5	3.8	0.18	0.9		70	10	5.1	2
Cafeteria/fast-food dining	7.5	3.8	0.18	0.9		100	9	4.7	2
Bars, cocktail lounges	7.5	3.8	0.18	0.9		100	9	4.7	2
Kitchen (cooking)	7.5	3.8	0.12	0.6		20	14	7.0	2
<b>General</b>									
Break rooms	5	2.5	0.06	0.3		25	10	5.1	1
Coffee stations	5	2.5	0.06	0.3		20	11	5.5	1
Conference/meeting	5	2.5	0.06	0.3		50	6	3.1	1
Corridors	–	–	0.06	0.3		–			1
Occupiable storage rooms for liquids or gels	5	2.5	0.12	0.6	B	2	65	32.5	2
<b>Hotels, Motels, Resorts, Dormitories</b>									
Bedroom/living room	5	2.5	0.06	0.3		10	11	5.5	1
Barracks sleeping areas	5	2.5	0.06	0.3		20	8	4.0	1
Laundry rooms, central	5	2.5	0.12	0.6		10	17	8.5	2
Laundry rooms within dwelling units	5	2.5	0.12	0.6		10	17	8.5	1
Lobbies/prefunction	7.5	3.8	0.06	0.3		30	10	4.8	1
Multipurpose assembly	5	2.5	0.06	0.3		120	6	2.8	1

**TABLE 6-1 MINIMUM VENTILATION RATES IN BREATHING ZONE (Continued)**  
 (This table is not valid in isolation; it must be used in conjunction with the accompanying notes.)

Occupancy Category	People Outdoor Air Rate		Area Outdoor Air Rate		Notes	Default Values		Air Class	
	$R_p$		$R_a$			Occupant Density (see Note 4)	Combined Outdoor Air Rate (see Note 5)		
	cfm/person	L/s-person	cfm/ft <sup>2</sup>	L/s-m <sup>2</sup>			#/1000 ft <sup>2</sup> or #/100 m <sup>2</sup>		cfm/person
<b>Office Buildings</b>									
Breakrooms	5	2.5	0.12	0.6		50	7	3.5	1
Main entry lobbies	5	2.5	0.06	0.3		10	11	5.5	1
Occupiable storage rooms for dry materials	5	2.5	0.06	0.3		2	35	17.5	1
Office space	5	2.5	0.06	0.3		5	17	8.5	1
Reception areas	5	2.5	0.06	0.3		30	7	3.5	1
Telephone/data entry	5	2.5	0.06	0.3		60	6	3.0	1
<b>Miscellaneous Spaces</b>									
Bank vaults/safe deposit	5	2.5	0.06	0.3		5	17	8.5	2
Banks or bank lobbies	7.5	3.8	0.06	0.3		15	12	6.0	1
Computer (not printing)	5	2.5	0.06	0.3		4	20	10.0	1
General manufacturing (excludes heavy industrial and processes using chemicals)	10	5.0	0.18	0.9		7	36	18	3
Pharmacy (prep. area)	5	2.5	0.18	0.9		10	23	11.5	2
Photo studios	5	2.5	0.12	0.6		10	17	8.5	1
Shipping/receiving	10	5	0.12	0.6	B	2	70	35	2
Sorting, packing, light assembly	7.5	3.8	0.12	0.6		7	25	12.5	2
Telephone closets	–	–	0.00	0.0		–			1
Transportation waiting	7.5	3.8	0.06	0.3		100	8	4.1	1
Warehouses	10	5	0.06	0.3	B	–			2
<b>Public Assembly Spaces</b>									
Auditorium seating area	5	2.5	0.06	0.3		150	5	2.7	1
Places of religious worship	5	2.5	0.06	0.3		120	6	2.8	1
Courtrooms	5	2.5	0.06	0.3		70	6	2.9	1
Legislative chambers	5	2.5	0.06	0.3		50	6	3.1	1
Libraries	5	2.5	0.12	0.6		10	17	8.5	1
Lobbies	5	2.5	0.06	0.3		150	5	2.7	1
Museums (children's)	7.5	3.8	0.12	0.6		40	11	5.3	1
Museums/galleries	7.5	3.8	0.06	0.3		40	9	4.6	1
<b>Residential</b>									
Dwelling unit	5	2.5	0.06	0.3	F,G	F			1
Common corridors	–	–	0.06	0.3					1
<b>Retail</b>									
Sales (except as below)	7.5	3.8	0.12	0.6		15	16	7.8	2
Mall common areas	7.5	3.8	0.06	0.3		40	9	4.6	1
Barbershop	7.5	3.8	0.06	0.3		25	10	5.0	2

**TABLE 6-1 MINIMUM VENTILATION RATES IN BREATHING ZONE (Continued)**  
(This table is not valid in isolation; it must be used in conjunction with the accompanying notes.)

Occupancy Category	People Outdoor		Area Outdoor		Notes	Default Values			Air Class
	Air Rate		Air Rate			Occupant Density (see Note 4)	Combined Outdoor Air Rate (see Note 5)		
	$R_p$		$R_a$				#/1000 ft <sup>2</sup> or #/100 m <sup>2</sup>	cfm/person	
	cfm/person	L/s-person	cfm/ft <sup>2</sup>	L/s·m <sup>2</sup>					
Beauty and nail salons	20	10	0.12	0.6		25	25	12.4	2
Pet shops (animal areas)	7.5	3.8	0.18	0.9		10	26	12.8	2
Supermarket	7.5	3.8	0.06	0.3		8	15	7.6	1
Coin-operated laundries	7.5	3.8	0.12	0.6		20	14	7.0	2
<b>Sports and Entertainment</b>									
Sports arena (play area)	–	–	0.30	1.5	E	–			1
Gym, stadium (play area)	–	–	0.30	1.5		30			2
Spectator areas	7.5	3.8	0.06	0.3		150	8	4.0	1
Swimming (pool & deck)	–	–	0.48	2.4	C	–			2
Disco/dance floors	20	10	0.06	0.3		100	21	10.3	2
Health club/aerobics room	20	10	0.06	0.3		40	22	10.8	2
Health club/weight rooms	20	10	0.06	0.3		10	26	13.0	2
Bowling alley (seating)	10	5	0.12	0.6		40	13	6.5	1
Gambling casinos	7.5	3.8	0.18	0.9		120	9	4.6	1
Game arcades	7.5	3.8	0.18	0.9		20	17	8.3	1
Stages, studios	10	5	0.06	0.3	D	70	11	5.4	1

GENERAL NOTES FOR TABLE 6-1

- 1 **Related requirements:** The rates in this table are based on all other applicable requirements of this standard being met.
- 2 **Environmental Tobacco Smoke:** This table applies to ETS-free areas. Refer to Section 5.17 for requirements for buildings containing ETS areas and ETS-free areas.
- 3 **Air density:** Volumetric airflow rates are based on an air density of 0.075 lb<sub>da</sub>/ft<sup>3</sup> (1.2 kg<sub>da</sub>/m<sup>3</sup>), which corresponds to dry air at a barometric pressure of 1 atm (101.3 kPa) and an air temperature of 70°F (21°C). Rates may be adjusted for actual density but such adjustment is not required for compliance with this standard.
- 4 **Default occupant density:** The default occupant density shall be used when actual occupant density is not known.
- 5 **Default combined outdoor air rate (per person):** This rate is based on the default occupant density.
- 6 **Unlisted occupancies:** If the occupancy category for a proposed space or zone is not listed, the requirements for the listed occupancy category that is most similar in terms of occupant density, activities and building construction shall be used.

ITEM-SPECIFIC NOTES FOR TABLE 6-1

- A For high school and college libraries, use values shown for Public Assembly Spaces—Libraries.
- B Rate may not be sufficient when stored materials include those having potentially harmful emissions.
- C Rate does not allow for humidity control. Additional ventilation or dehumidification may be required to remove moisture. “Deck area” refers to the area surrounding the pool that would be expected to be wetted during normal pool use, i.e., when the pool is occupied. Deck area that is not expected to be wetted shall be designated as a space type (for example, “spectator area”).
- D Rate does not include special exhaust for stage effects, e.g., dry ice vapors, smoke.
- E When combustion equipment is intended to be used on the playing surface, additional dilution ventilation and/or source control shall be provided.
- F Default occupancy for dwelling units shall be two persons for studio and one-bedroom units, with one additional person for each additional bedroom.
- G Air from one residential dwelling shall not be recirculated or transferred to any other space outside of that dwelling.

different sources can be applied to any other aspect of indoor air quality.

**6.2.2.1.1 Design Zone Population.** Design zone population ( $P_z$ ) shall equal the largest (peak) number of people expected to occupy the *ventilation zone* during typical usage.

**Exceptions:**

- a. If the number of people expected to occupy the *ventilation zone* fluctuates, zone population equal to the average number of people shall be permitted, provided such average is determined in accordance with Section 6.2.6.2.

- b. If the largest or average number of people expected to occupy the *ventilation zone* cannot be established for a specific design, an estimated value for zone population shall be permitted, provided such value is the product of the *net occupiable area* of the *ventilation zone* and the default occupant density listed in Table 6-1.

**6.2.2.2 Zone Air Distribution Effectiveness.** The zone air distribution effectiveness ( $E_z$ ) shall be no greater than the default value determined using Table 6-2.

**Note:** For some configurations, the default value depends upon space and supply air temperature.



**6.2.2.3 Zone Outdoor Airflow.** The zone outdoor airflow ( $V_{oz}$ ), i.e., the outdoor airflow rate that must be provided to the *ventilation zone* by the supply air distribution system, shall be determined in accordance with Equation 6-2.

$$V_{oz} = V_{bz}/E_z \quad (6-2)$$

**6.2.3 Single-Zone Systems.** For ventilation systems wherein one or more air handlers supply a mixture of *outdoor air* and *recirculated air* to only one *ventilation zone*, the outdoor air intake flow ( $V_{ot}$ ) shall be determined in accordance with Equation 6-3.

$$V_{ot} = V_{oz} \quad (6-3)$$

**6.2.4 100% Outdoor Air Systems.** For ventilation systems wherein one or more air handlers supply only *outdoor air* to one or more *ventilation zones*, the outdoor air intake flow ( $V_{ot}$ ) shall be determined in accordance with Equation 6-4.

$$V_{ot} = \sum_{all\ zones} V_{oz} \quad (6-4)$$

**6.2.5 Multiple-Zone Recirculating Systems.** For ventilation systems wherein one or more air handlers supply a mixture of *outdoor air* and *recirculated air* to more than one *ventilation zone*, the outdoor air intake flow ( $V_{ot}$ ) shall be determined in accordance with Sections 6.2.5.1 through 6.2.5.4.

**6.2.5.1 Primary Outdoor Air Fraction.** Primary outdoor air fraction ( $Z_{pz}$ ) shall be determined for *ventilation zones* in accordance with Equation 6-5.

$$Z_{pz} = V_{oz}/V_{pz} \quad (6-5)$$

where  $V_{pz}$  is the zone primary airflow, i.e., the primary airflow rate to the *ventilation zone* from the air handler, including outdoor air and recirculated air.

**Note:** For VAV-system design purposes,  $V_{pz}$  is the lowest zone primary airflow value expected at the design condition analyzed.

**Note:** In some cases it is acceptable to determine these parameters for only selected zones as outlined in Normative Appendix A.

**6.2.5.2 System Ventilation Efficiency.** The system ventilation efficiency ( $E_v$ ) shall be determined in accordance with Table 6-3 or Normative Appendix A.

**6.2.5.3 Uncorrected Outdoor Air Intake.** The uncorrected outdoor air intake ( $V_{ou}$ ) flow shall be determined in accordance with Equation 6-6.

$$V_{ou} = D \sum_{all\ zones} (R_p \cdot P_z) + \sum_{all\ zones} (R_a \cdot A_z) \quad (6-6)$$

**6.2.5.3.1 Occupant Diversity.** The occupant diversity ratio ( $D$ ) shall be determined in accordance with Equation 6-7 to account for variations in population within the *ventilation zones* served by the system.

$$D = P_s / \sum_{all\ zones} P_z, \quad (6-7)$$

where the system population ( $P_s$ ) is the total population in the area served by the system.

**Exception:** Alternative methods to account for occupant diversity shall be permitted, provided that the result-

**TABLE 6-2 Zone Air Distribution Effectiveness**

Air Distribution Configuration	$E_z$
Ceiling supply of cool air.	1.0
Ceiling supply of warm air and floor return.	1.0
Ceiling supply of warm air 15°F (8°C) or more above space temperature and ceiling return.	0.8
Ceiling supply of warm air less than 15°F (8°C) above space temperature and ceiling return provided that the 150 fpm (0.8 m/s) supply air jet reaches to within 4.5 ft (1.4 m) of floor level. <b>Note:</b> For lower velocity supply air, $E_z = 0.8$ .	1.0
Floor supply of cool air and ceiling return provided that the 150 fpm (0.8 m/s) supply jet reaches 4.5 ft (1.4 m) or more above the floor. <b>Note:</b> Most underfloor air distribution systems comply with this proviso.	1.0
Floor supply of cool air and ceiling return, provided low-velocity displacement ventilation achieves unidirectional flow and thermal stratification.	1.2
Floor supply of warm air and floor return.	1.0
Floor supply of warm air and ceiling return.	0.7
Makeup supply drawn in on the opposite side of the room from the exhaust and/or return.	0.8
Makeup supply drawn in near to the exhaust and/or return location.	0.5

1. "Cool air" is air cooler than space temperature.
2. "Warm air" is air warmer than space temperature.
3. "Ceiling" includes any point above the *breathing zone*.
4. "Floor" includes any point below the *breathing zone*.
5. As an alternative to using the above values,  $E_z$  may be regarded as equal to air change effectiveness determined in accordance with ANSI/ASHRAE Standard 129<sup>17</sup> for all air distribution configurations except unidirectional flow.

**TABLE 6-3 System Ventilation Efficiency**

Max ( $Z_p$ )	$E_v$
≤0.15	1.0
≤0.25	0.9
≤0.35	0.8
≤0.45	0.7
≤0.55	0.6
>0.55	Use Appendix A

1. "Max ( $Z_p$ )" refers to the largest value of  $Z_{pz}$ , calculated using Equation 6-5, among all the *ventilation zones* served by the system.
2. For values of Max ( $Z_p$ ) between 0.15 and 0.55, the corresponding value of  $E_v$  may be determined by interpolating the values in the table.
3. The values of  $E_v$  in this table are based on a 0.15 average outdoor air fraction for the system (i.e., the ratio of the uncorrected outdoor air intake ( $V_{ou}$ ) to the total zone primary airflow for all the zones served by the air handler). For systems with higher values of the average outdoor air fraction, this table may result in unrealistically low values of  $E_v$  and the use of Appendix A may yield more practical results.

ing  $V_{ou}$  value is no less than that determined using Equation 6-6.

**Note:** The uncorrected outdoor air intake ( $V_{ou}$ ) is adjusted for occupant diversity, but it is not corrected for system ventilation efficiency.

**6.2.5.3.2 Design System Population.** Design system population ( $P_s$ ) shall equal the largest (peak) number of

people expected to occupy all *ventilation zones* served by the ventilation system during typical usage.

**Note:** Design system population is always equal to or less than the sum of design zone population for all zones in the area served by the system, since all zones may or may not be simultaneously occupied at design population.

**6.2.5.4 Outdoor Air Intake.** The design outdoor air intake flow ( $V_{ot}$ ) shall be determined in accordance with Equation 6-8.

$$V_{ot} = V_{ov}/E_v \quad (6-8)$$

## 6.2.6 Design for Varying Operating Conditions

**6.2.6.1 Variable Load Conditions.** Ventilation systems shall be designed to be capable of providing no less than the minimum ventilation rates required in the breathing zone whenever the zones served by the system are occupied, including all full- and part-load conditions.

**Note:** The minimum outdoor air intake flow may be less than the design value at part-load conditions.

**6.2.6.2 Short-Term Conditions.** If it is known that peak occupancy will be of short duration and/or ventilation will be varied or interrupted for a short period of time, the design may be based on the average conditions over a time period ( $T$ ) determined by Equation 6-9a using I-P units (Equation 6-9b using SI units).

$$T = 3v/V_{bz} \quad (\text{I-P}) \quad (6-9a)$$

$$T = 50v/V_{bz} \quad (\text{SI}) \quad (6-9b)$$

where

$T$  = averaging time period, min

$v$  = the volume of the *ventilation zone* for which averaging is being applied, ft<sup>3</sup> (m<sup>3</sup>)

$V_{bz}$  = the breathing zone outdoor airflow calculated using Equation 6-1 and the design value of the zone population ( $P_z$ ), cfm (L/s)

Acceptable design adjustments based on this optional provision include the following:

- Zones with fluctuating occupancy: the zone population ( $P_z$ ) may be averaged over time ( $T$ ).
- Zones with intermittent interruption of supply air: the average outdoor airflow supplied to the *breathing zone* over time ( $T$ ) shall be no less than the breathing zone outdoor airflow ( $V_{bz}$ ) calculated using Equation 6-1.
- Systems with intermittent closure of the outdoor air intake: the average outdoor air intake over time ( $T$ ) shall be no less than the minimum outdoor air intake ( $V_{ot}$ ) calculated using Equation 6-3, 6-4, or 6-8 as appropriate.

**6.2.7 Dynamic Reset.** The system may be designed to reset the outdoor air intake flow ( $V_{ot}$ ) and/or space or ventilation zone airflow ( $V_{oz}$ ) as operating conditions change.

### 6.2.7.1 Demand Control Ventilation (DCV)

**6.2.7.1.1** DCV shall be permitted as an optional means of dynamic reset.

**Exception:** CO<sub>2</sub>-based DCV shall not be applied in zones with indoor sources of CO<sub>2</sub> other than occupants or with CO<sub>2</sub> removal mechanisms, such as gaseous air cleaners.

**6.2.7.1.2** The breathing zone outdoor airflow ( $V_{bz}$ ) shall be reset in response to current occupancy and shall be no less than the building component ( $R_a \cdot A_z$ ) of the DCV zone.

**Note:** Examples of reset methods or devices include population counters, carbon dioxide (CO<sub>2</sub>) sensors, timers, occupancy schedules or occupancy sensors.

**6.2.7.1.3** The ventilation system shall be controlled such that at steady-state it provides each zone with no less than the breathing zone outdoor airflow ( $V_{bz}$ ) for the current zone population.

**6.2.7.1.4** When the mechanical air-conditioning system is dehumidifying, the current total outdoor air intake flow for the building shall be no less than the coincident total exhaust airflow.

**6.2.7.1.5 Documentation.** A written description of the equipment, methods, control sequences, set points, and the intended operational functions shall be provided. A table shall be provided that shows the minimum and maximum outdoor intake airflow for each system.

**6.2.7.2 Ventilation Efficiency.** Variations in the efficiency with which outdoor air is distributed to the occupants under different ventilation system airflows and temperatures shall be permitted as an optional basis of dynamic reset.

**6.2.7.3 Outdoor Air Fraction.** A higher fraction of outdoor air in the air supply due to intake of additional outdoor air for free cooling or exhaust air makeup shall be permitted as an optional basis of dynamic reset.

**6.3 Indoor Air Quality (IAQ) Procedure.** Breathing zone outdoor airflow ( $V_{bz}$ ) and/or system outdoor air intake flow ( $V_{ot}$ ) shall be determined in accordance with Sections 6.3.1 through 6.3.5.

**6.3.1 Contaminant Sources.** Contaminants or mixtures of concern for purposes of the design shall be identified. For each contaminant or mixture of concern, indoor sources (occupants and materials) and outdoor sources shall be identified, and the emission rate for each contaminant of concern from each source shall be determined.

**Note:** Appendix B lists information for some potential contaminants of concern.

**6.3.2 Contaminant Concentration.** For each contaminant of concern, a concentration limit and its corresponding exposure period and an appropriate reference to a cognizant authority shall be specified.

**Note:** Appendix B includes concentration guidelines for some potential contaminants of concern.

**6.3.3 Perceived Indoor Air Quality.** The design level of indoor air acceptability shall be specified in terms of the percentage of building occupants and/or visitors expressing satisfaction with perceived IAQ.

**6.3.4 Design Approach.** Zone and system outdoor airflow rates shall be the larger of those determined in accordance with Section 6.3.4.1 and either 6.3.4.2 or 6.3.4.3, based on emission rates, concentration limits, and other relevant

design parameters (e.g., air cleaning efficiencies and supply airflow rates).

**6.3.4.1 Mass Balance Analysis.** Using a steady-state or dynamic mass-balance analysis, determine the minimum outdoor airflow rates required to achieve the concentration limits specified in Section 6.3.2 for each contaminant or mixture of concern within each zone served by the system.

*Notes:*

- a. Appendix D includes steady-state mass-balance equations that describe the impact of air cleaning on outdoor air and recirculation rates for ventilation systems serving a single zone.
- b. In the completed building, measurement of the concentration of contaminants or mixtures of concern may be useful as a means of checking the accuracy of the design mass-balance analysis, but such measurement is not required for compliance.

**6.3.4.2 Subjective Evaluation.** Using a subjective occupant evaluation conducted in the completed building, determine the minimum outdoor airflow rates required to achieve the level of acceptability specified in Section 6.3.3 within each zone served by the system.

*Notes:*

- a. Appendix B presents one approach to subjective occupant evaluation.
- b. Level of acceptability often increases in response to increased outdoor airflow rates, increased level of indoor and/or outdoor air cleaning, or decreased indoor and/or outdoor contaminant emission rate.

**6.3.4.3 Similar Zone.** The minimum outdoor airflow rates shall be no less than those found in accordance with Section 6.3.4.2 for a substantially similar zone (i.e., in a zone with identical contaminants of concern, concentration limits, air cleaning efficiency, and specified level of acceptability; and with similar contaminant sources and emission rates).

**6.3.5 Combined IAQ Procedure and Ventilation Rate Procedure.** The IAQ procedure in conjunction with the Ventilation Rate Procedure may be applied to a zone or system. In this case, the Ventilation Rate Procedure shall be used to determine the required zone minimum outdoor airflow, and the IAQ Procedure shall be used to determine the additional outdoor air or air cleaning necessary to achieve the concentration limits of the contaminants of concern.

*Note:* The improvement of indoor air quality through the use of air cleaning or provision of additional outdoor air in conjunction with minimum ventilation rates may be quantified using the IAQ procedure.

**6.3.6 Documentation.** When the IAQ Procedure is used, the following information shall be included in the design documentation: the contaminants of concern considered in the design process, the sources and emission rates of the contaminants of concern, the concentration limits and exposure periods and the references for these limits, and the analytical

approach used to determine ventilation rates and air cleaning requirements. The contaminant monitoring and occupant and/or visitor evaluation plans shall also be included in the documentation.

**6.4 Natural Ventilation Procedure.** Natural ventilation systems shall be designed in accordance with this section and shall include mechanical ventilation systems designed in accordance with Section 6.2 and/or Section 6.3.

**Exceptions:**

- a. An engineered natural ventilation system, when approved by the authority having jurisdiction, need not meet the requirements of Section 6.4.
- b. The mechanical ventilation systems are not required when:
  1. Natural ventilation openings that comply with the requirements of Section 6.4 are permanently open or have controls that prevent the openings from being closed during periods of expected occupancy, or
  2. The zone is not served by heating or cooling equipment.

**6.4.1 Floor Area to Be Ventilated.** Spaces, or portions of spaces, to be naturally ventilated must be located within a distance based on the ceiling height, as determined by Sections 6.4.1.1, 6.4.1.2, or 6.4.1.3, from operable wall openings that meet the requirements of Section 6.4.2. For spaces with ceilings which are not parallel to the floor, the ceiling height shall be determined in accordance with Section 6.4.1.4.

**6.4.1.1 Single Side Opening.** For spaces with operable openings on one side of the space, the maximum distance from the operable openings is  $2H$ , where  $H$  is the ceiling height.

**6.4.1.2 Double Side Opening.** For spaces with operable openings on two opposite sides of the space, the maximum distance from the operable openings is  $5H$ , where  $H$  is the ceiling height.

**6.4.1.3 Corner Openings.** For spaces with operable openings on two adjacent sides of a space (i.e. two sides of a corner), the maximum distance from the operable openings is  $5H$  along a line drawn between the two openings which are farthest apart. Floor area outside that line must comply with Section 6.4.1.1.

**6.4.1.4 Ceiling Height.** The ceiling height,  $H$ , to be used in Sections 6.4.1.1 through 6.4.1.3 shall be the minimum ceiling height in the space.

**Exception:** For ceilings that are increasing in height as distance from the openings is increased, the ceiling height shall be determined as the average height of the ceiling within 6 m (20 ft.) from the operable openings.

**6.4.2 Location and Size of Openings.** Spaces, or portions of spaces, to be naturally ventilated shall be permanently open to operable wall openings directly to the outdoors, the openable area of which is a minimum of 4% of the net occupiable floor area. Where openings are covered with louvers or otherwise obstructed, openable area shall be based on the net free unobstructed area through the opening. Where interior rooms,

or portions of rooms, without direct openings to the outdoors are ventilated through adjoining rooms, the opening between rooms shall be permanently unobstructed and have a free area of not less than 8% of the area of the interior room nor less than 25 ft<sup>2</sup> (2.3 m<sup>2</sup>).

**6.4.3 Control and Accessibility.** The means to open required operable openings shall be readily accessible to building occupants whenever the space is occupied. Controls shall be designed to properly coordinate operation of the natural and mechanical ventilation systems.

**6.5 Exhaust Ventilation.** The design exhaust airflow shall be determined in accordance with the requirements in Table 6-4. Exhaust makeup air may be any combination of outdoor air, recirculated air, and transfer air.

**6.6 Design Documentation Procedures.** Design criteria and assumptions shall be documented and should be made available for operation of the system within a reasonable time after installation. See Sections 4.3, 5.1.3, 5.16.4, 6.2.7.1.5, and 6.3.6 regarding assumptions that should be detailed in the documentation.

## 7. CONSTRUCTION AND SYSTEM START-UP

### 7.1 Construction Phase

**7.1.1 Application.** The requirements of this section apply to ventilation systems and the spaces they serve in new buildings and additions to or alterations in existing buildings.

**7.1.2 Filters.** Systems designed with particle filters shall not be operated without filters in place.

**TABLE 6-4 Minimum Exhaust Rates**

Occupancy Category	Exhaust Rate, cfm/unit	Exhaust Rate, cfm/ft <sup>2</sup>	Notes	Exhaust Rate, L/s-unit	Exhaust Rate, L/s-m <sup>2</sup>	Air Class
Arenas	—	0.50	B	—	—	1
Art classrooms	—	0.70		—	3.5	2
Auto repair rooms	—	1.50	A	—	7.5	2
Barber shops	—	0.50		—	2.5	2
Beauty and nail salons	—	0.60		—	3.0	2
Cells with toilet	—	1.00		—	5.0	2
Copy, printing rooms	—	0.50		—	2.5	2
Darkrooms	—	1.00		—	5.0	2
Educational science laboratories	—	1.00		—	5.0	2
Janitor closets, trash rooms, recycling	—	1.00		—	5.0	3
Kitchenettes	—	0.30		—	1.5	2
Kitchens—commercial	—	0.70		—	3.5	2
Locker/dressing rooms	—	0.25		—	1.25	2
Locker rooms	—	0.50		—	2.5	2
Paint spray booths	—	—	F	—	—	4
Parking garages	—	0.75	C	—	3.7	2
Pet shops (animal areas)	—	0.90		—	4.5	2
Refrigerating machinery rooms	—	—	F	—	—	3
Residential kitchens	50/100	—	G	25/50	—	2
Soiled laundry storage rooms	—	1.00	F	—	5.0	3
Storage rooms, chemical	—	1.50	F	—	7.5	4
Toilets—private	25/50	—	E	12.5/25	—	2
Toilets—public	50/70	—	D	25/35	—	2
Woodwork shop/classrooms	—	0.50		—	2.5	2

- A Stands where engines are run shall have exhaust systems that directly connect to the engine exhaust and prevent escape of fumes.
- B When combustion equipment is intended to be used on the playing surface additional dilution ventilation and/or source control shall be provided.
- C Exhaust not required if two or more sides comprise walls that are at least 50% open to the outside.
- D Rate is per water closet and/or urinal. Provide the higher rate where periods of heavy use are expected to occur, e.g., toilets in theatres, schools, and sports facilities. The lower rate may be used otherwise.
- E Rate is for a toilet room intended to be occupied by one person at a time. For continuous system operation during normal hours of use, the lower rate may be used. Otherwise use the higher rate.
- F See other applicable standards for exhaust rate.
- G For continuous system operation, the lower rate may be used. Otherwise use the higher rate.

**7.1.3 Protection of Materials.** When recommended by the manufacturer, building materials shall be protected from rain and other sources of moisture by appropriate in-transit and on-site procedures. Porous materials with visible microbial growth shall not be installed. Nonporous materials with visible microbial growth shall be decontaminated.

#### 7.1.4 Protection of Occupied Areas

**7.1.4.1 Application.** The requirements of Section 7.1.4 apply when construction requires a building permit and entails sanding, cutting, grinding, or other activities that generate significant amounts of airborne particles or procedures that generate significant amounts of gaseous contaminants.

**7.1.4.2 Protective Measures.** Measures shall be employed to reduce the migration of construction-generated contaminants to occupied areas. Examples of acceptable measures include, but are not limited to, sealing the construction area using temporary walls or plastic sheathing, exhausting the construction area, and/or pressurizing contiguous occupied areas.

**7.1.5 Air Duct System Construction.** Air duct systems shall be constructed in accordance with the following standards, as applicable:

- a. The following sections of SMACNA's *HVAC Duct Construction Standards—Metal and Flexible*:<sup>18</sup>
  - Section S1.9 of Section 1.3.1, Duct Construction and Installation Standards
  - Section 7.4, Installation Standards for Rectangular Ducts Using Flexible Liner
  - Section 3.5, Duct Installation Standards
  - Section 3.6, Specification for Joining and Attaching Flexible Duct
  - Section 3.7, Specification for Supporting Flexible Duct
  - Sections S6.1, S6.3, S6.4, and S6.5 of Section 9.1, Casing and Plenum Construction Standards
- b. All sections of SMACNA's *Fibrous Glass Duct Construction Standards*<sup>19</sup>
- c. *NFPA 90A*,<sup>20</sup> *Standard for the Installation of Air-Conditioning and Ventilating Systems*, and *NFPA 90B*,<sup>21</sup> *Standard for the Installation of Warm Air Heating and Air-Conditioning Systems*

## 7.2 System Start-Up

**7.2.1 Application.** The requirements of this section apply to the following ventilation systems:

- a. Newly installed air-handling systems.
- b. Existing air-handling systems undergoing supply air or outdoor airflow reduction—only the requirements of Section 7.2.2 shall apply to these altered systems.
- c. Existing air-handling distribution systems undergoing alterations affecting more than 25% of the floor area served by the systems—only the requirements of Section 7.2.2 shall apply to these altered systems.

**7.2.2 Air Balancing.** Ventilation systems shall be balanced in accordance with ASHRAE Standard 111,<sup>16</sup> SMACNA's *HVAC Systems—Testing, Adjusting and Balanc-*

*ing*,<sup>22</sup> or equivalent at least to the extent necessary to verify conformance with the total outdoor airflow and space supply airflow requirements of this standard.

**7.2.3 Testing of Drain Pans.** To minimize conditions of water stagnation that may result in microbial growth, drain pans shall be field tested under normal operating conditions to ensure proper drainage.

**Exception:** Field testing of drain pans is not required if units with factory-installed drain pans have been certified (attested in writing) by the manufacturer for proper drainage when installed as recommended.

**7.2.4 Ventilation System Start-Up.** Ventilation air distribution systems shall be clean of dirt and debris.

**7.2.5 Outdoor Air Dampers.** Prior to occupancy, each ventilation system shall be tested to ensure that outdoor air dampers operate properly in accordance with the system design.

**7.2.6 Documentation.** The following ventilation system documentation shall be provided to the building owner or his/her designee, retained within the building, and made available to the building operating personnel:

- a. An operating and maintenance manual describing basic data relating to the operation and maintenance of ventilation systems and equipment as installed.
- b. HVAC controls information consisting of diagrams, schematics, control sequence narratives, and maintenance and/or calibration information.
- c. An air balance report documenting the work performed for Section 7.2.2.
- d. Construction drawings of record, control drawings, and final design drawings.
- e. Design criteria and assumptions.

## 8. OPERATIONS AND MAINTENANCE

### 8.1 General

**8.1.1 Application.** The requirements of this section apply to buildings and their ventilation systems and their components constructed or renovated after the adoption date of this section.

**8.1.2 Building Alterations or Change-of-Use.** Ventilation system design, operation, and maintenance shall be reevaluated when changes in building use or occupancy category, significant building alterations, significant changes in occupant density, or other changes inconsistent with system design assumptions are made.

**8.2 Operations and Maintenance Manual.** An Operations and Maintenance (O&M) Manual, either written or electronic, shall be developed and maintained on site or in a centrally accessible location for the working life of the applicable ventilation system equipment or components. This manual shall be updated as necessary. The manual shall include the O&M procedures, ventilation system operating schedules and any changes made thereto, final design drawings, maintenance schedules and any changes made thereto, and the maintenance requirements and frequencies detailed in Section 8.4.

**8.3 Ventilation System Operation.** Mechanical and natural ventilation systems shall be operated in a manner consistent with the O&M Manual. Systems shall be operated such that spaces are ventilated in accordance with Section 6 when they are expected to be occupied.

**8.4 Ventilation System Maintenance**

**8.4.1 Ventilation System Components.** The building ventilation system components shall be maintained in accordance with the O&M Manual or as required by this section and summarized in Table 8-1.

**8.4.1.1 Filters and Air-Cleaning Devices.** All filters and air-cleaning devices shall be replaced or maintained as specified by the O&M Manual.

**8.4.1.2 Outdoor Air Dampers.** At a minimum of once every three months or as specified in the O&M Manual, the outdoor air dampers and actuators shall be visually inspected or remotely monitored to verify that they are functioning in accordance with the O&M Manual.

**8.4.1.3 Humidifiers.** Humidifiers shall be cleaned and maintained to limit fouling and microbial growth. These sys-

tems shall be inspected at a minimum of once every three months of operation and/or treated as specified in the O&M Manual.

**8.4.1.4 Dehumidification Coils.** All dehumidifying cooling coils shall be visually inspected for cleanliness and microbial growth regularly when it is likely that dehumidification occurs but no less than once per year or as specified in the O&M Manual and shall be cleaned when fouling or microbial growth is observed.

**8.4.1.5 Drain Pans.** Drain pans shall be visually inspected for cleanliness and microbial growth at a minimum of once per year during the cooling season or as specified in the O&M Manual and shall be cleaned if needed. Areas adjacent to drain pans that were subjected to wetting shall be investigated, cleaned if necessary, and the cause of unintended wetting rectified.

**8.4.1.6 Outdoor Air Intake Louvers.** Outdoor air intake louvers, bird screens, mist eliminators, and adjacent areas shall be visually inspected for cleanliness and integrity at a minimum of once every six months or as specified in the

**TABLE 8-1 Minimum Maintenance Activity and Frequency**

Item	Activity Code	Minimum Frequency*
Filters and air-cleaning devices	A	According to O&M Manual
Outdoor air dampers and actuators	B	Every three months or in accordance with O&M Manual
Humidifiers	C	Every three months of use or in accordance with O&M Manual
Dehumidification coils	D	Regularly when it is likely that dehumidification occurs but no less than once per year or as specified in the O&M Manual
Drain pans and other adjacent surfaces subject to wetting	D	Once per year during cooling season or as specified in the O&M Manual
Outdoor air intake louvers, bird screens, mist eliminators, and adjacent areas	E	Every six months or as specified in the O&M Manual
Sensors used for dynamic minimum outdoor air control	F	Every six months or periodically in accordance with O&M Manual
Air-handling systems except for units under 2000 cfm (1000 L/s)	G	Once every five years
Cooling towers	H	In accordance with O&M Manual or treatment system provider
Floor drains located in plenums or rooms that serve as air plenums	I	Periodically according to O&M Manual
Equipment/component accessibility	J	
Visible microbial contamination	K	
Water intrusion or accumulation	K	

**ACTIVITY CODE:**

- A Maintain according to O&M Manual.
- B Visually inspect or remotely monitor for proper function.
- C Clean and maintain to limit fouling and microbial growth.
- D Visually inspect for cleanliness and microbial growth and clean when fouling is observed.
- E Visually inspect for cleanliness and integrity and clean when necessary.
- F Verify accuracy and recalibrate or replace as necessary.
- G Measure minimum quantity of outdoor air. If measured minimum airflow rates are less than 90% of the minimum outdoor air rate in the O&M Manual, they shall be adjusted or modified to bring them above 90% or shall be evaluated to determine if the measured rates are in conformance with this standard.
- H Treat to limit the growth of microbiological contaminants.
- I Maintain to prevent transport of contaminants from the floor drain to the plenum.
- J Keep clear the space provided for routine maintenance and inspection around ventilation equipment.
- K Investigate and rectify.

\* Minimum frequencies may be increased or decreased if indicated in the O&M Manual.

O&M Manual and cleaned as needed. When visible debris or visible biological material is observed, it shall be removed. Physical damage to louvers, screens, or mist eliminators shall be repaired if such damage impairs their function in preventing contaminant entry.

**8.4.1.7 Sensors.** Sensors whose primary function is dynamic minimum outdoor air control, such as flow stations at an air handler and those used for demand control ventilation, shall have their accuracy verified as specified in the O&M Manual. This activity shall occur at a minimum of once every six months or periodically in accordance with the O&M Manual. A sensor failing to meet the accuracy specified in the O&M Manual shall be recalibrated or replaced.

**8.4.1.8 Outdoor Airflow Verification.** The total quantity of outdoor air to air handlers except for units under 2000 cfm (1000 L/s) of supply air shall be measured in minimum outdoor air mode once every five years. If measured minimum airflow rates are less than the design minimum rate ( $\pm 10\%$  balancing tolerance) documented in the O&M Manual, they shall be adjusted or modified to bring them to the minimum design rate or evaluated to determine if the measured rates are in compliance with this standard.

**8.4.1.9 Cooling Towers.** Cooling tower water systems shall be treated to limit the growth of microbiological contaminants including *legionella sp.* in accordance with the O&M Manual or the water treatment program.

**8.4.1.10 Equipment/Component Accessibility.** The space provided for routine maintenance and inspection around ventilation equipment shall be kept clear.

**8.4.1.11 Floor Drains.** Floor drains located in air plenums or rooms that serve as plenums shall be maintained to prevent transport of contaminants from the floor drain to the plenum.

**8.4.2 Microbial Contamination.** Visible microbial contamination shall be investigated and rectified.

**8.4.3 Water Intrusion.** Water intrusion or accumulation in ventilation system components such as ducts, plenums, and air handlers shall be investigated and rectified.

## 9. REFERENCES

- <sup>1</sup>*National Primary and Secondary Ambient Air Quality Standards*, Code of Federal Regulations, Title 40 Part 50 (40 CFR 50), as amended July 30, 2004 and Oct. 17, 2006. U.S. Environmental Protection Agency. [www.epa.gov/air/criteria.html](http://www.epa.gov/air/criteria.html), accessed June 20, 2008.
- <sup>2</sup>*HVAC Air Duct Leakage Test Manual*, First Edition, 1985. Sheet Metal and Air Conditioning Contractors' Association, Inc. (SMACNA), Chantilly, VA.
- <sup>3</sup>*UL 181, Factory-Made Air Ducts and Air Connectors*, 10th Edition, 2005. Underwriters' Laboratories, Inc., Northbrook, IL.
- <sup>4</sup>*ASTM C 1338-00, Standard Test Method for Determining Fungi Resistance of Insulation Materials and Facings*. American Society for Testing and Materials, West Conshohocken, PA.

- <sup>5</sup>*NFPA-45-2004, Standard on Fire Protection for Laboratories Using Chemicals*. National Fire Protection Association, Quincy, MA.
- <sup>6</sup>*ANSI/AIHA Z9.5-2003, Standard for Laboratory Ventilation*. American Industrial Hygiene Association, Fairfax, VA.
- <sup>7</sup>*Industrial Ventilation: A Manual of Recommended Practice*, 26th Edition, 2007. American Conference of Governmental Industrial Hygienists (ACGIH), Committee on Industrial Ventilation, Lansing, MI.
- <sup>8</sup>*2007 ASHRAE Handbook—Heating, Ventilating, and Air-Conditioning Applications*. American Society of Heating, Refrigerating and Air-Conditioning Engineers, Inc., Atlanta, GA.
- <sup>9</sup>*ANSI Z223.1/NFPA-54-2006, National Fuel Gas Code*. National Fire Protection Association, Quincy, MA.
- <sup>10</sup>*NFPA-31-2006, Installation of Oil-Burning Equipment*. National Fire Protection Association, Quincy, MA.
- <sup>11</sup>*NFPA-211-2006, Standard for Chimneys, Fireplaces, Vents, and Solid Fuel-Burning Appliances*. National Fire Protection Association, Quincy, MA.
- <sup>12</sup>*UL 1995, Heating and Cooling Equipment*, 3rd Edition, 2005. Underwriters Laboratories, Inc., Northbrook, IL.
- <sup>13</sup>*AMCA 500-L-07, Laboratory Methods of Testing Louvers for Rating*. Air Movement and Control Association International, Inc. Arlington Heights, IL.
- <sup>14</sup>*AMCA 511-07, Certified Ratings Program—Product Rating Manual for Air Control Devices*. Air Movement and Control Association International, Inc. Arlington Heights, IL.
- <sup>15</sup>*ANSI/ASHRAE Standard 52.2-2007, Method of Testing General Ventilation Air-Cleaning Devices for Removal Efficiency by Particle Size*. American Society of Heating, Refrigerating and Air-Conditioning Engineers, Inc., Atlanta, GA.
- <sup>16</sup>*ASHRAE Standard 111-1988, Practices for Measurement, Testing, Adjusting, and Balancing of Building, Heating, Ventilation, Air-Conditioning and Refrigeration Systems*. American Society of Heating, Refrigerating and Air-Conditioning Engineers, Inc., Atlanta, GA.
- <sup>17</sup>*ANSI/ASHRAE 129-1997 (RA 02), Measuring Air Change Effectiveness*. American Society of Heating, Refrigerating and Air-Conditioning Engineers, Inc., Atlanta, GA.
- <sup>18</sup>*ANSI/SMACNA 006-2006 HVAC Duct Construction Standards—Metal and Flexible*, 3rd Edition, 2005. Sheet Metal and Air Conditioning Contractors' National Association, Inc. (SMACNA), Chantilly, VA.
- <sup>19</sup>*Fibrous Glass Duct Construction Standards*, 7th Edition, 2003. Sheet Metal and Air Conditioning Contractors' National Association, Inc. (SMACNA), Chantilly, VA.
- <sup>20</sup>*NFPA-90A-2002, Standard for the Installation of Air-Conditioning and Ventilating Systems*. National Fire Protection Association, Quincy, MA.
- <sup>21</sup>*NFPA-90B-2006, Standard for the Installation of Warm Air Heating and Air-Conditioning Systems*. National Fire Protection Association, Quincy, MA.
- <sup>22</sup>*HVAC Systems—Testing, Adjusting and Balancing*, 3rd Edition, 2002. Sheet Metal and Air Conditioning Contractors' National Association, Inc. (SMACNA), Chantilly, VA.

(This is a normative appendix and is part of the standard.)

## NORMATIVE APPENDIX A MULTIPLE-ZONE SYSTEMS

This appendix presents an alternative procedure for calculating the system ventilation efficiency ( $E_v$ ) that must be used when Table 6-3 values are not used. In this alternative procedure,  $E_v$  is equal to the lowest calculated value of the zone ventilation efficiency ( $E_{vz}$ ) (see Equation A-8 below). Figure A-1 contains a ventilation system schematic depicting most of the quantities used in this appendix.

### A1. SYSTEM VENTILATION EFFICIENCY

For any multiple-zone recirculating system, the system ventilation efficiency ( $E_v$ ) shall be calculated in accordance with Sections A1.1 through A1.3.

**A1.1 Average Outdoor Air Fraction.** The average outdoor air fraction ( $X_s$ ) for the ventilation system shall be determined in accordance with Equation A-1.

$$X_s = V_{out}/V_{ps} \quad (A-1)$$

where the uncorrected outdoor air intake ( $V_{out}$ ) is found in accordance with Section 6.2.5.3, and the system primary airflow ( $V_{ps}$ ) is found at the condition analyzed.

**Note:** For VAV system design purposes,  $V_{ps}$  is the highest expected system primary airflow at the design condition analyzed. System primary airflow at design is usually less than the sum of design zone primary airflow values, since primary airflow seldom peaks simultaneously in all VAV zones.

**A1.2 Zone Ventilation Efficiency.** The zone ventilation efficiency ( $E_{vz}$ ), i.e., the efficiency with which a system distributes outdoor air from the intake to an individual *breathing zone*, shall be determined in accordance with Section A1.2.1 or A1.2.2.

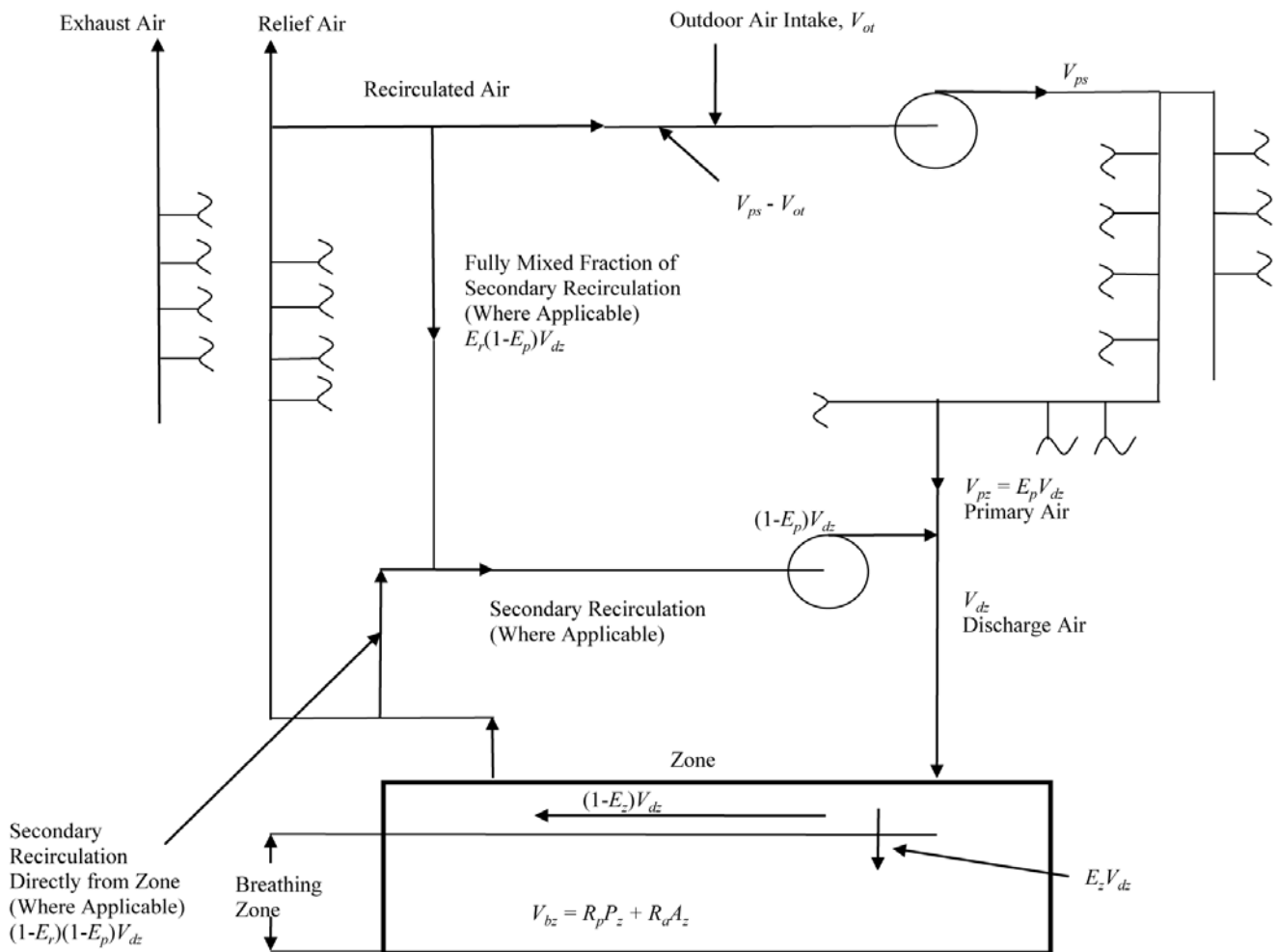

Figure A-1 Ventilation system schematic.



**A1.2.1 Single-Supply Systems.** For “single supply” systems, wherein all of the air supplied to each *ventilation zone* is a mixture of outdoor air and system-level *recirculated air*, zone ventilation efficiency ( $E_{vz}$ ) shall be determined in accordance with Equation A-2. Examples of single-supply systems include constant volume reheat, single-duct VAV, single-fan dual-duct, and multizone systems.

$$E_{vz} = 1 + X_s - Z_{pz} \quad (\text{A-2})$$

where the average outdoor air fraction ( $X_s$ ) for the system is determined in accordance with Equation A-1 and the primary outdoor air fraction ( $Z_{pz}$ ) for the zone is determined in accordance with Section 6.2.5.1.

**A1.2.2 Secondary Recirculation Systems.** For “secondary-recirculation” systems wherein all or part of the supply air to each *ventilation zone* is *recirculated air* (which has not been directly mixed with outdoor air) from other zones, zone ventilation efficiency ( $E_{vz}$ ) shall be determined in accordance with Equation A-3. Examples of secondary-recirculation systems include dual-fan dual-duct and fan-powered mixing-box systems, and systems that include transfer fans for conference rooms.

$$E_{vz} = (F_a + X_s \cdot F_b - Z_{pz} \cdot E_p \cdot F_c) / F_a \quad (\text{A-3})$$

where system air fractions  $F_a$ ,  $F_b$ , and  $F_c$  are determined in accordance with Equation A-4, A-5, and A-6, respectively.

$$F_a = E_p + (1 - E_p) \cdot E_r \quad (\text{A-4})$$

$$F_b = E_p \quad (\text{A-5})$$

$$F_c = 1 - (1 - E_z) \cdot (1 - E_r) \cdot (1 - E_p) \quad (\text{A-6})$$

where the zone primary air fraction ( $E_p$ ) is determined in accordance with Equation A-7; zone secondary recirculation fraction ( $E_r$ ) is determined by the designer based on system configuration; and zone air distribution effectiveness ( $E_z$ ) is determined in accordance with Section 6.2.2.2.

**Note:** For plenum return systems with secondary recirculation (e.g., fan-powered VAV with plenum return)  $E_r$  is usually less than 1.0, although values may range from 0.1 to 1.2 depending upon the location of the *ventilation zone* relative to other zones and the air handler. For ducted return systems with secondary recirculation (e.g., fan-powered VAV with ducted return),  $E_r$  is typically 0.0, while for those with system-level recirculation (e.g., dual-fan dual-duct systems with ducted return)  $E_r$  is typically 1.0. For other system types,  $E_r$  is typically 0.75.

$$E_p = V_{pz} / V_{dz} \quad (\text{A-7})$$

where  $V_{dz}$  is zone discharge airflow.

**Note:** For single-zone and single-supply systems,  $E_p$  is 1.0.

**A1.3 System Ventilation Efficiency.** The system ventilation efficiency shall equal the lowest zone ventilation efficiency among all ventilation zones served by the air handler, in accordance with Equation A-8.

$$E_v = \text{minimum}(E_{vz}) \quad (\text{A-8})$$

## A2. ALTERNATIVE CALCULATIONS

Mass or flow balance equations for multiple-zone systems may be used to determine system ventilation efficiency and other design parameters, provided that they result in outdoor air intake airflow ( $V_{ot}$ ) that is within 5% of the airflow value obtained using the system ventilation efficiency ( $E_v$ ) calculated using Equation A-8 or they more accurately represent a particular system configuration.

## A3. DESIGN PROCESS

The system ventilation efficiency and therefore the outdoor air intake flow for the system ( $V_{ot}$ ) determined as part of the design process are based on the design and minimum expected supply air flows to individual ventilation zones as well as the design outdoor air requirements to the zones. For VAV system design purposes, zone ventilation efficiency ( $E_{vz}$ ) for each *ventilation zone* shall be found using the minimum expected zone primary airflow ( $V_{pz}$ ) and using the highest expected system primary airflow ( $V_{ps}$ ) at the design condition analyzed.

**Note:** Increasing the zone supply air flow values during the design process, particularly to the critical zones requiring the highest fraction of outdoor air, reduces the system outdoor air intake flow requirement determined in the calculation.

**A3.1 Selecting Zones for Calculation.** Zone ventilation efficiency ( $E_{vz}$ ) shall be calculated for all *ventilation zones*.

**Exception:** Since system ventilation efficiency ( $E_v$ ) is determined by the minimum value of the zone ventilation efficiency ( $E_{vz}$ ), in accordance with Equation A-8, calculation of  $E_{vz}$  is not required for any *ventilation zone* that has an  $E_{vz}$  value that is equal to or larger than that of the *ventilation zone* for which a calculation has been done.

**Note:** The value of  $E_{vz}$  for a *ventilation zone* will be equal to or larger than that for another *ventilation zone* if all of the following are true relative to the other *ventilation zone*:

- Floor area per occupant ( $A_z/P_z$ ) is no lower
- Minimum zone discharge airflow rate per unit area ( $V_{dz}/A_z$ ) is no lower
- Primary air fraction ( $E_p$ ) is no lower
- Zone air distribution effectiveness ( $E_z$ ) is no lower
- Area outdoor air rate ( $R_a$ ) is no higher
- People outdoor air rate ( $R_p$ ) is no higher

**Example:** In office buildings, it is generally only necessary to calculate  $E_{vz}$  for one typical interior *ventilation zone*, since the parameters listed above are generally equal for all interior spaces. If overhead supply air is used to heat the perimeter, it is generally also necessary to calculate  $E_{vz}$  for the perimeter zone with the lowest expected primary or discharge airflow rate per unit area. No other calculations for  $E_{vz}$  are typically necessary, even if the building has 1000 *ventilation zones*, provided the ventilation for any conference rooms or non-office occupancy zones are separately calculated.

#### A4. SYMBOLS

$A_z$  **Zone Floor Area:** The net occupiable floor area of the *ventilation zone* ft<sup>2</sup> (m<sup>2</sup>).

$D$  **Occupant Diversity:** The ratio of the system population to the sum of the zone populations.

$E_p$  **Primary Air Fraction:** The fraction of primary air in the discharge air to the *ventilation zone*.

$E_r$  **Secondary Recirculation Fraction:** In systems with secondary recirculation of return air, the fraction of secondary recirculated air to the zone that is representative of average system return air rather than air directly recirculated from the zone.

$E_v$  **System Ventilation Efficiency:** The efficiency with which the system distributes air from the outdoor air intake to the *breathing zone* in the ventilation-critical zone, which requires the largest fraction of outdoor air in the primary air stream.

*Note:*  $E_v$  may be determined in accordance with Section 6.2.5.2 or Section A1.

$E_{vz}$  **Zone Ventilation Efficiency:** The efficiency with which the system distributes air from the outdoor air intake to the breathing zone in any particular *ventilation zone*.

$E_z$  **Zone Air Distribution Effectiveness:** A measure of the effectiveness of supply air distribution to the *breathing zone*.

*Note:*  $E_z$  is determined in accordance with Section 6.2.2.2.

$F_a$  **Supply Air Fraction:** The fraction of supply air to the *ventilation zone* that includes sources of air from outside the zone.

$F_b$  **Mixed Air Fraction:** The fraction of supply air to the *ventilation zone* from fully mixed primary air.

$F_c$  **Outdoor Air Fraction:** The fraction of outdoor air to the *ventilation zone* that includes sources of air from outside the zone.

$P_s$  **System Population:** The simultaneous number of occupants in the area served by the ventilation system.

$P_z$  **Zone Population:** See Section 6.2.2.1.

$R_a$  **Area Outdoor Air Rate:** See Section 6.2.2.1.

$R_p$  **People Outdoor Air Rate:** See Section 6.2.2.1.

$V_{bz}$  **Breathing Zone Outdoor Airflow:** see Section 6.2.2.1.

$V_{dz}$  **Zone Discharge Airflow:** The expected discharge (supply) airflow to the zone that includes primary airflow and secondary recirculated airflow, cfm (L/s).

$V_{ot}$  **Outdoor Air Intake Flow:** See Sections 6.2.3, 6.2.4, 6.2.5.4.

$V_{ou}$  **Uncorrected Outdoor Air Intake:** See Section 6.2.5.3.

$V_{oz}$  **Zone Outdoor Airflow:** See Section 6.2.2.3.

$V_{ps}$  **System Primary Airflow:** The total primary airflow supplied to all zones served by the system from the air-handling unit at which the outdoor air intake is located.

$V_{pz}$  **Zone Primary Airflow:** See Section 6.2.5.1.

$X_s$  **Average Outdoor Air Fraction:** At the primary air handler, the fraction of outdoor air intake flow in the system primary airflow.

$Z_{pz}$  **Primary Outdoor Air Fraction:** The outdoor air fraction required in the primary air supplied to the *ventilation zone* prior to the introduction of any secondary recirculation air

**(This appendix is not part of this standard. It is merely informative and does not contain requirements necessary for conformance to the standard. It has not been processed according to the ANSI requirements for a standard and may contain material that has not been subject to public review or a consensus process. Unresolved objectors on informative material are not offered the right to appeal at ASHRAE or ANSI.)**

## **INFORMATIVE APPENDIX B SUMMARY OF SELECTED AIR QUALITY GUIDELINES**

If particular contaminants are of concern, or if the IAQ Procedure is to be used, acceptable indoor concentrations and exposures are needed for the particular contaminants. When using this procedure, these concentration and exposure values need to be documented and justified by reference to a cognizant authority as defined in the standard. Such guidelines or other limiting values can also be useful for diagnostic purposes. At present, no single organization develops acceptable concentrations or exposures for all indoor air contaminants, nor are values available for all contaminants of potential concern. A number of organizations offer guideline values for selected indoor air contaminants. These values have been developed primarily for ambient air, occupational settings, and, in some cases, for residential settings. They should be applied with an understanding of their basis and applicability to the indoor environment of concern. If an acceptable concentration or exposure has not been published for a contaminant of concern, a value may be derived through review of the toxicological and epidemiological evidence using appropriate consultation. However, the evidence with respect to health effects is likely to be insufficient for many contaminants. At present, there is no quantitative definition of acceptable IAQ that can necessarily be met by measuring one or more contaminants.

Table B-1 presents selected standards and guidelines used in Canada, Germany, Europe, and the United States for acceptable concentrations of substances in ambient air, indoor air, and industrial workplace environments. These values are issued by cognizant authorities and have not been developed or endorsed by ASHRAE. The table is presented only as background information when using the IAQ Procedure. Specialized expertise should be sought before selecting a value for use in estimating outdoor airflow rates using the IAQ Procedure or for building design or diagnostics purposes. Meeting one, some, or all of the listed values does not ensure that acceptable IAQ (as defined in this standard) will be achieved.

Tables B-2 and B-3 list concentration values of interest for selected contaminants as general guidance for building design, diagnostics, and ventilation system design using the IAQ Procedure. The values in the table are based on cognizant authorities and studies reported in peer-reviewed scientific publications; ASHRAE does not recommend their adoption as regulatory values, standards, or guidelines. The tables are presented as further background when using the IAQ Procedure. Consultation should be sought before selecting a partic-

ular value for use in calculating ventilation using the IAQ Procedure. Meeting one, some, or all of the listed values does not ensure that acceptable IAQ will be achieved.

Selection of a specific target concentration and exposure is best made by a team with wide experience in toxicology, industrial hygiene, and exposure assessment. As they review the specific concentrations listed in Tables B-1, B-2, and B-3, or others taken from other sources, designers should be mindful of the following:

- Standards and guidelines are developed for different purposes and should be interpreted with reference to the setting and purpose for which they were developed compared to that to which they are being applied.
- Not all standards and guideline values recognize the presence of susceptible groups or address typical populations found in occupancies listed in this standard.
- Most standards and guidelines do not consider interactions between and among various contaminants of concern.
- The assumptions and conditions set forth by the standard or guideline may not be met in the space or for the occupants being considered (such as 8-hour day, 40-hour work week).

When many chemicals are present in the air, as they almost always are in indoor air, then some way of addressing potential additive effects is warranted. The ACGIH guidance on the subject instructs that when two or more substances acting on the "...same organ system are present, their combined effect, rather than that of either individually, should be given primary consideration." <sup>B-1</sup> Information on affected organs is readily available on the websites of the cited references for ACGIH, OEHHA, and ATSDR. If no contradictory information is available, the effects of the different substances "should be considered as additive." A formula is given wherein the ratios of the concentrations of each substance with the same health-related endpoint to the threshold-limit value for each substance are added. If the sum of all these ratios exceeds unity, then it is considered that the concentration value has been exceeded.

$$\frac{C_1}{T_1} + \frac{C_2}{T_2} + \dots + \frac{C_n}{T_n}$$

where

$C_i$  = the airborne concentration of the substance, and

$T_i$  = the threshold-limit value of that substance.

### **Guideline Values for Industrial Environments**

ACGIH threshold limit values, or TLVs<sup>®</sup>, have been applied to industrial workplace air contaminants. <sup>B-1</sup> (Reference B-2 is the German counterpart.) The ACGIH TLVs<sup>®</sup> represent maximum acceptable 8-hour, time-weighted average (TWA), 15-minute short-term exposure limit (STEL) and instantaneous (ceiling) case limits. It is a source of concentration limits for many chemical substances and physical agents for industrial use. In light of the constantly changing state of

knowledge, the document is updated annually. It cautions the user, "The values listed in this book are intended for use in the practice of industrial hygiene as guidelines or recommendations to assist in the control of potential health hazards and for no other use."

Caution must be used in directly extending the ACGIH TLVs<sup>®</sup> or other workplace guidelines to spaces covered by this standard and to population groups other than workers. Industrial health practice attempts to limit worker exposure to injurious substances at levels that do not interfere with the industrial work process and do not risk the workers' health and safety. There is not an intention to eliminate all effects, such as unpleasant smells or mild irritation. Further, the health criteria are not uniformly derived for all contaminants. Irritation, narcosis, and nuisance or other forms of stress are not uniformly considered as the basis for the concentration limits. This is because different organizations use different end points and different contaminants have more or less information available on diverse end points of interest. The target population is also different from the occupants found in the spaces covered by this standard. Healthy industrial workers tend to change jobs or occupations if an exposure becomes intolerable. In contrast, workers in commercial environments such as offices often do not expect elevated concentrations of potentially harmful substances in their work environments. Also, monitoring programs are unlikely to be in place, as may be the case with industrial workplaces. In addition, the general population may have less choice about where they spend most of their time and includes those who may be more sensitive, such as children, asthmatics, allergic individuals, the sick, and the elderly.

### **Guidelines for Substances in Outdoor Air**

Guidelines have been developed for outdoor air for a number of chemicals and metals, as shown in many of the references. These values, including some for metals, may be appropriate for some indoor environments, but they should be applied only after appropriate consultation. These guidelines also provide guidance concerning the quality of outside air if there is suspicion that outdoor air may be contaminated with specific substances or if there is a known source of contamination nearby.<sup>B-3</sup>

### **Regulation of Occupational Exposure to Airborne Contaminants**

Regulations of occupational exposure to workplace hazards are based on the results of accumulated experience with worker health and toxicological research and carefully evaluated by groups of experts. Effects are examined in relation to exposure to the injurious substance. Exposure is defined as the mathematical product of the concentration of the contaminant and the time during which a person is exposed to this concentration. Since concentration may vary with time, exposure is typically calculated across the appropriate averaging time, expressed as a TWA concentration, STEL, or ceiling limit. Regulations of the U.S. Occupational Safety and Health Administration (OSHA) are TWAs in most cases.

Industrial exposures are regulated on the basis of a 40-hour workweek with 8- to 10-hour days. During the remainder of the time, exposure is anticipated to be substantially lower for the contaminants of concern. Application of industrial exposure limits would not necessarily be appropriate for other indoor settings, occupancies, and exposure scenarios. However, for certain contaminants that lack exposure limits for a specific nonindustrial target population, substantial downward adjustments to occupational limits have sometimes been used.

### **Substances Lacking Guidelines and Standards**

For indoor contaminants for which an acceptable concentration and exposure value has not been established by a cognizant authority, one approach has been to assume that some fraction of TLV<sup>®</sup> is applicable and would not lead to adverse health effects or complaints in general populations. This approach should not be used without first assessing its suitability for the contaminant of concern. In any event, if appropriate standards or guidelines do not exist, expertise must be sought or research needs to be conducted to determine contaminant concentrations and exposures that are acceptable.

### **Subjective Evaluation**

Indoor air often contains complex mixtures of contaminants of concern such as environmental tobacco smoke,<sup>B-30,B-31</sup> infectious and allergenic biological aerosols,<sup>B-32</sup> and emissions of chemicals from commercial and consumer products. Precise quantitative treatment of these contaminants can be difficult or impossible in most cases. Chemical composition alone may not always be adequate to reliably predict the reaction of building occupants exposed to most common mixtures of substances found in indoor air. There are many toxicological endpoints used in assessing the effects from exposure to air contaminants.

Irritation of mucosal tissue such as that found in the human nose, eyes, and the upper airways is one of the endpoints often used in assessing short-term exposure to air contaminants. These irritation responses can occur after the "irritant receptor" is exposed to nonreactive compounds, to reactive compounds with a different pattern of dose-response relationships, and through allergic and other immunologic effects for which dose-response relationships have not been well defined. Susceptible populations, i.e., individuals with atopy ("allergies") may report irritation at lower levels of exposures than individuals without allergies. Other susceptible populations, such as the elderly and the young, may differ from healthy adults in their response to irritating and odorous substances.

To some degree, adequacy of control may rest upon subjective evaluation. Panels of observers have been used to perform subjective evaluation of IAQ in buildings. Many contaminants have odors or are irritants that may be detected by human occupants or visitors to a space. Generally the air can be considered acceptably free of annoying contaminants if 80% of a panel consisting of a group of untrained subjects exposed to known concentrations of contaminants under representative controlled conditions of use and occupancy deems the air not to be objectionable.

## Guide for Using TABLE B-1

The substances listed in Table B-1 are common air contaminants in industrial and nonindustrial environments. The values summarized in this table are from various sources with diverse procedures and criteria for establishing the values. Some are for industrial environments (OSHA, MAK, NIOSH, ACGIH), some are for outdoor environments (NAAQS), and others are general (WHO) or indoor residential environment-related (Canadian) values. The following explanations are intended to assist the reader by providing a brief description of the criteria each agency used in adopting its guideline values.

- NAAQS: Outdoor air standards developed by the U.S. EPA under the Clean Air Act. By law, the values listed in these regulations must be reviewed every five years. These concentrations are selected to protect not only the general population but also the most sensitive individuals.
- OSHA: Enforceable maximum exposures for industrial environments developed by OSHA (U.S. Department of Labor) through a formal rule-making process. Once an exposure limit has been set, levels can be changed only through reopening the rule-making process. These permissible exposure limits (PELs) are not selected to protect the most sensitive individuals.
- MAK: Recommended maximum exposures for industrial environments developed by the Deutsche Forschungs Gemeinschaft, a German institution similar to the U.S. National Institutes of Health and NIOSH. Levels are set on a regular basis, with annual reviews and periodic republication of criteria levels. These levels are enforceable in Germany and are not selected to protect the most sensitive individuals.
- Canadian: Recommended maximum exposures for residences developed in 1987 and reaffirmed in 1995 by a committee of provincial members convened by the federal government to establish consensus guideline-type levels. A revised version is being considered. These are not intended to be enforced.
- WHO/Europe: Environmental (nonindustrial) guidelines developed in 1987 and updated in 1999 by the WHO Office for Europe (Denmark). Intended for application both to indoor and outdoor exposure.
- NIOSH: Recommended maximum exposure guidelines for industrial environments are developed by NIOSH (Centers for Disease Control) and published in a series of criteria documents. NIOSH criteria documents contain both a review of the literature and a recommended exposure limit (REL) guideline. These are not enforceable, are not reviewed regularly, and are not selected to protect the most sensitive individuals. In some cases, they are set at levels above those deemed protective of health because commonly available industrial hygiene practice does not reliably detect the substances at lower levels. (Note that methods used in nonindustrial settings are often more sensitive than NIOSH methods for industrial hygiene measurements.)
- ACGIH: Recommended maximum exposures for industrial environments developed by ACGIH's Threshold Limit Values (TLVs<sup>®</sup>) Committee. The committee reviews the scientific literature and recommends exposure guidelines. The assumptions are for usual industrial working conditions, 40-hour weeks, and single exposures. Surveillance practices for both exposures and biological responses are often in place in the work environments where these levels are used. These levels are not selected to protect the most sensitive individuals. About half of the TLVs<sup>®</sup> are intended to protect against irritation. Published studies have shown that many of the TLVs<sup>®</sup> intended to protect against irritation actually represent levels where some or all of the study subjects did report irritation.<sup>B-33, B-34</sup>

The table is not inclusive of all contaminants in indoor air, and achieving the listed indoor concentrations for all of the listed substances does not ensure odor acceptability, avoidance of sensory irritation, or all adverse health effects for all occupants. In addition to indoor contaminant levels, the acceptability of indoor air also involves thermal conditions, indoor moisture levels as they impact microbial growth, and other indoor environmental factors. ASHRAE is not selecting or recommending default concentrations.

Users of this table should recognize that unlisted noxious contaminants can also cause unacceptable IAQ with regard to comfort (sensory irritation), odors, and health. When such contaminants are known or might reasonably be expected to be present, selection of an acceptable concentration and exposure may require reference to other guidelines or a review and evaluation of relevant toxicological and epidemiological literature.

**TABLE B-1 Comparison of Regulations and Guidelines Pertinent to Indoor Environments<sup>a</sup>**  
 (The user of any value in this table should take into account the purpose for which it was adopted and the means by which it was developed.)

	Enforceable and/or Regulatory Levels			Non-Enforced Guidelines and Reference Levels			
	NAAQS/EPA (Ref. B-4)	OSHA (Ref. B-5)	MAK (Ref. B-2)	Canadian (Ref. B-8)	WHO/Europe (Ref. B-11)	NIOSH (Ref. B-13)	ACGIH (Ref. B-1)
Carbon dioxide		5000 ppm	5000 ppm 10,000 ppm [1 h]	3500 ppm [L]		5000 ppm 30,000 ppm [15 min]	5000 ppm 30,000 ppm [15 min]
Carbon monoxide <sup>c</sup>	9 ppm <sup>g</sup> 35 ppm [1 h] <sup>g</sup>	50 ppm	30 ppm 60 ppm [30 min]	11 ppm [8 h] 25 ppm [1 h]	90 ppm [15 min] 50 ppm [30 min] 25 ppm [1 h] 10 ppm [8 h]	35 ppm 200 ppm [C]	25 ppm
Formaldehyde <sup>h</sup>		0.75 ppm 2 ppm [15 min]	0.3 ppm 1 ppm <sup>i</sup>	0.1 ppm [L] 0.05 ppm [L] <sup>b</sup>	0.1 mg/m <sup>3</sup> (0.081 ppm) [30 min] <sup>p</sup>	0.016 ppm 0.1 ppm [15 min]	0.3 ppm [C]
Lead	1.5 µg/m <sup>3</sup> [3 months]	0.05 mg/m <sup>3</sup>	0.1 mg/m <sup>3</sup> 1 mg/m <sup>3</sup> [30 min]	Minimize exposure	0.5 µg/m <sup>3</sup> [1 yr]	0.050 mg/m <sup>3</sup>	0.05 mg/m <sup>3</sup>
Nitrogen dioxide	0.05 ppm [1 yr]	5 ppm [C]	5 ppm 10 ppm [5 min]	0.05 ppm 0.25 ppm [1 h]	0.1 ppm [1 h] 0.02 ppm [1 yr]	1 ppm [15 min]	3 ppm 5 ppm [15 min]
Ozone	0.12 ppm [1 h] <sup>g</sup> 0.08 ppm	0.1 ppm	j	0.12 ppm [1 h]	0.064 ppm (120 µg/m <sup>3</sup> ) [8 h]	0.1 ppm [C]	0.05 ppm <sup>k</sup> 0.08 ppm <sup>l</sup> 0.1 ppm <sup>m</sup> 0.2 ppm <sup>n</sup>
Particles <sup>e</sup> <2.5 µm MMAD <sup>d</sup>	15 µg/m <sup>3</sup> [1 yr] <sup>o</sup> 35 µg/m <sup>3</sup> [24 h] <sup>o</sup>	5 mg/m <sup>3</sup>	1.5 mg/m <sup>3</sup> for <4 µm	0.1 mg/m <sup>3</sup> [1 h] 0.040 mg/m <sup>3</sup> [L]			3 mg/m <sup>3</sup> [C]
Particles <sup>e</sup> <10 µm MMAD <sup>d</sup>	150 µg/m <sup>3</sup> [24 h] <sup>o</sup>		4 mg/m <sup>3</sup>				10 mg/m <sup>3</sup> [C]
Radon				800 Bq/m <sup>3</sup> [1 yr]			
Sulfur dioxide	0.03 ppm [1 yr] 0.14 ppm [24 h] <sup>g</sup>	5 ppm	0.5 ppm 1 ppm <sup>i</sup>	0.38 ppm [5 min] 0.019 ppm	0.048 ppm [24 h] 0.012 ppm [1 yr]	2 ppm 5 ppm [15 min]	2 ppm 5 ppm [15 min]
Total Particles <sup>e</sup>		15 mg/m <sup>3</sup>					

<sup>a</sup> Numbers in brackets [ ] refer to either a ceiling or to averaging times of less than or greater than eight hours (min = minutes; h = hours; y = year; C = ceiling, L = long-term). Where no time is specified, the averaging time is eight hours.  
<sup>b</sup> Target level is 0.05 ppm because of its potential carcinogenic effects. Total aldehydes limited to 1 ppm. Although the epidemiological studies conducted to date provide little convincing evidence that formaldehyde is carcinogenic in human populations, because of this potential, indoor levels should be reduced as much as possible.  
<sup>c</sup> As one example regarding the use of values in this table, readers should consider the applicability of carbon monoxide concentrations. The concentrations considered acceptable for nonindustrial, as opposed to industrial, exposure are substantially lower. These lower concentrations (in other words, the ambient air quality standards, which are required to consider populations at highest risk) are set to protect the most sensitive subpopulation, individuals with pre-existing heart conditions.  
<sup>d</sup> MMAD = mass median aerodynamic diameter in microns (micrometers). Less than 3.0 µm is considered respirable; less than 10 µm is considered inhalable.  
<sup>e</sup> Nuisance particles not otherwise classified (PNOC), not known to contain significant amounts of asbestos, lead, crystalline silica, known carcinogens, or other particles known to cause significant adverse health effects.  
<sup>f</sup> See Table B-2 for the U.S. EPA guideline.  
<sup>g</sup> Not to be exceeded more than once per year.  
<sup>h</sup> The U.S. Department of Housing and Urban Development adopted regulations concerning formaldehyde emissions from plywood and particleboard intended to limit the airborne concentration of formaldehyde in manufactured homes to 0.4 ppm. (24 CFR Part 3280, HUD Manufactured Home Construction and Safety Standards). In addition, California Air Resources Board Regulation §93120, entitled "Airborne Toxic Control Measure to Reduce Formaldehyde Emissions from Composite Wood Products" has specific chamber-based requirements for composite wood products sold in California. <sup>B-47</sup>  
<sup>i</sup> Never to be exceeded.  
<sup>j</sup> Carcinogen, no maximum values established.  
<sup>k</sup> TLV<sup>®</sup> for heavy work.  
<sup>l</sup> TLV<sup>®</sup> for moderate work.  
<sup>m</sup> TLV<sup>®</sup> for light work.  
<sup>n</sup> TLV<sup>®</sup> for heavy, moderate, or light workloads (less than or equal to two hours).  
<sup>o</sup> 62FR38652 - 38760, July 16, 1997.  
<sup>p</sup> Epidemiological studies suggest a causal relationship between exposure to formaldehyde and nasopharyngeal cancer, although the conclusion is tempered by the small numbers of observed and expected cases. There are also epidemiological observations of an association between relatively high occupational exposures to formaldehyde and sinonasal cancer.

### Guide for Using TABLE B-2

The substances listed in Table B-2 are common air contaminants of concern in nonindustrial environments. The target concentrations that have been set or proposed by various national or international organizations concerned with health and comfort effects of outdoor and indoor air are listed for reference only. The table is not inclusive of all contaminants in indoor air, and achieving the target indoor concentrations for all of the listed substances does not ensure freedom from sensory irritation or from all adverse health effects for all occupants. In addition to indoor contaminant levels, the acceptability of indoor air also involves thermal conditions, indoor moisture levels as they impact microbial growth, and other indoor environmental factors. ASHRAE is not selecting or recommending default concentrations.

Health or comfort effects and exposure periods that are the basis for the guideline levels are listed in the “comments” column. For design, the goal should be to meet the guideline levels continuously during occupancy because people spend the great majority of their time indoors.

Users of this table should recognize that unlisted noxious contaminants can also cause unacceptable IAQ with regard to comfort (sensory irritation), odors, and health. When such contaminants are known or might reasonably be expected to be present, selection of an acceptable concentration and exposure may require reference to other guidelines or a review and evaluation of relevant toxicological and epidemiological literature. (Table B-2 summarizes some of this literature.)

**TABLE B-2 Concentration of Interest for Selected Contaminants**

(Note: References numbers that are followed by [c] and [m] list the concentrations of interest [c] and measurement methods [m].)  
 (Note: The user of any value in this table should take into account the purpose for which it was adopted and the means by which it was developed.)

Contaminant	Sources	Concentrations of Interest	Comments	References
Carbon Monoxide (CO)	Leaking vented combustion appliances	9 ppm (8 h)	Based on effects on persons with coronary artery disease, average exposure for eight hours.	B-4 [c]
	Unvented combustion appliances Parking garages Outdoor air		Sustained indoor concentrations exceeding outdoor concentrations may merit further investigation. Many carbon monoxide measuring instruments have limited accuracy at low levels. Sources—burning of gasoline, natural gas, coal, oil, etc. Health effects—reduces ability of blood to bring oxygen to body cells and tissues; cells and tissues need oxygen to work. Carbon monoxide may be particularly hazardous to people who have heart or circulatory problems and people who have damaged lungs or breathing passages.	B-9 [m]
Formaldehyde (HCHO)	Pressed-wood products Furniture and furnishings	0.1 mg/m <sup>3</sup> (0.081 ppm) (30 min)	Based on irritation of sensitive people, 30-minute exposure (WHO).	B-11 [c] B-9, 26 [m]
		27 ppb (8 h)	Established as a never-to-exceed guideline to avoid irritant effects in sensitive individuals. Does not protect against formaldehyde's potential carcinogenicity (California Air Resources Board).	B-16
	45 ppb (55 µg/m <sup>3</sup> ) (1 h) 7.3 ppb (9 µg/m <sup>3</sup> ) (8 h)	Acute and 8-hour noncancer Reference Exposure Levels (RELs) developed based on current scientific database (Cal-EPA, OEHHA).	B-36	
		Health effects—Acute and chronic inhalation exposure to formaldehyde in humans can result in eye, nose, and throat irritation, respiratory symptoms, exacerbation of asthma, and sensitization. Human studies have reported an association between formaldehyde exposure and lung and nasopharyngeal cancer. In 2004, the International Agency for Research on Cancer (IARC) concluded that “ <i>formaldehyde is carcinogenic to humans (Group 1)</i> , on the basis of <i>sufficient evidence</i> in humans and <i>sufficient evidence</i> in experimental animals.”	B-19, 20, 36, 40	
		16 ppb	FEMA Procurement Specification for Mobile Homes	B-48

**TABLE B-2 Concentration of Interest for Selected Contaminants (Continued)**

(Note: References numbers that are followed by [c] and [m] list the concentrations of interest [c] and measurement methods [m].)  
 (Note: The user of any value in this table should take into account the purpose for which it was adopted and the means by which it was developed.)

Contaminant	Sources	Concentrations of Interest	Comments	References
Lead (Pb)	Paint dust	1.5 µg/m <sup>3</sup>	Based on adverse effects on neuropsychological functioning of children, average exposure for three months (WHO: 0.5-1 µg/m <sup>3</sup> for 1 year). Sources—leaded gasoline (being phased out), paint (houses, cars), smelters (metal refineries), manufacture of lead storage batteries. Health effects—brain and other nervous system damage; children are at special risk. Some lead-containing chemicals cause cancer in animals. Lead causes digestive and other health problems. Environmental effects—Lead can harm wildlife.	B-4 [c]
	Outdoor air			B-4 [m] B-18
Nitrogen Dioxide (NO <sub>2</sub> )	Leaking vented combustion appliances	100 µg/m <sup>3</sup>	Based on providing protection against adverse respiratory effects, average exposure for one year.	B-4 [c] B-9 [m]
	Unvented combustion appliances Outdoor air		Sources—burning of gasoline, natural gas, coal, oil, etc. Cars are an important source of NO <sub>2</sub> outdoors and cooking and water- and space-heating devices are important sources indoors. Health effects—lung damage, illnesses of breathing passages and lungs (respiratory system). Environmental effects—Nitrogen dioxide is a component of acid rain (acid aerosols), which can damage trees and lakes. Acid aerosols can reduce visibility. Property damage—Acid aerosols can eat away stone used on buildings, statues, monuments, etc.	B-18
		470 µg/m <sup>3</sup>	24-hour average to prevent high exposures during use of combustion appliances such as space-heating devices and gas stoves.	B-41
Odors	Occupants VOC sources (including fungal sources such as mold) Cooking, food processing, sewage, biowaste facilities, etc.	Predicted (or measured) acceptability to 80% or more of occupants or visitors	CO <sub>2</sub> concentration can be used as a surrogate for occupant odors (odorous bioeffluents). See Appendix C for a discussion of indoor CO <sub>2</sub> levels and ventilation rates. For sources other than people, source control is recommended.	B-12, 24, 29, 30 [c] B-9 (CO <sub>2</sub> ), B-15 (odor) [m]
Ozone (O <sub>3</sub> )	Electrostatic appliances	100 µg/m <sup>3</sup> (50 ppb)	Based on 25% increase in symptom exacerbations among adults or asthmatics (normal activity), eight-hour exposure (WHO); continuous exposure (FDA). Ozone present at levels below the concentration of interest may contribute to the degradation of indoor air quality directly and by reacting with other contaminants in the indoor space. Ground-level ozone is the principal component of smog. Sources—outdoors, from chemical reaction of pollutants, VOCs, and NO <sub>x</sub> ; indoors, from photocopiers, laser printers, ozone generators, electrostatic precipitators, and some other air cleaners. Health effects—breathing problems, reduced lung function, asthma, irritated eyes, stuffy nose, reduced resistance to colds and other infections. May speed up aging of lung tissue. Environmental effects—Outdoors, ozone can damage plants and trees; smog can cause reduced visibility. Property damage—Indoors and outdoors, ozone damages natural and synthetic rubbers, plastics, fabrics, etc.	B-6, 11 [c] B-6 [m]
	Office machines Ozone generators Outdoor air			B-18
Particles (PM <sub>2.5</sub> )	Combustion products, cooking, candles, incense, resuspension, and outdoor air	15 µg/m <sup>3</sup>		B-4



**TABLE B-2 Concentration of Interest for Selected Contaminants (Continued)**

(Note: References numbers that are followed by [c] and [m] list the concentrations of interest [c] and measurement methods [m].)  
 (Note: The user of any value in this table should take into account the purpose for which it was adopted and the means by which it was developed.)

Contaminant	Sources	Concentrations of Interest	Comments	References
Particles (PM <sub>10</sub> )	Dust Smoke Deteriorating materials Outdoor air	50 µg/m <sup>3</sup>	Based on protecting against respiratory morbidity in the general population and avoiding exacerbation of asthma, average exposure for one year, no carcinogens. Indoor concentrations are normally lower; guideline level may lead to unacceptable deposition of “dust.” Sources—burning of wood, diesel, and other fuels; industrial plants; agriculture (plowing, burning off fields); unpaved roads. Health effects—nose and throat irritation, lung damage, bronchitis, early death. Environmental effects—Particulates are the main source of haze that reduces visibility. Property damage—Ashes, soot, smoke, and dust can dirty and discolor structures and other property, including clothes and furniture.	B-4 [c] B-4 [m]  B-18
Radon (Rn)	Soil gas	4 pCi/L <sup>a</sup>	Based on lung cancer, average exposure for one year.	B-7 [c,m] B-10 [m]
Sulfur Dioxide (SO <sub>2</sub> )	Unvented space heaters (kerosene) Outdoor air	80 µg/m <sup>3</sup>	Based on protecting against respiratory morbidity in the general population and avoiding exacerbation of asthma, average exposure for one year (WHO: 50 µg/m <sup>3</sup> if with PM). Source—burning of coal and oil, especially high-sulfur coal from the eastern United States; industrial processes (paper, metals). Health effects—breathing problems; may cause permanent damage to lungs. Environmental effects—SO <sub>2</sub> is a component of acid rain (acid aerosols), which can damage trees and lakes. Acid aerosols can also reduce visibility. Property damage—Acid aerosols can eat away stone used in buildings, statues, monuments, etc.	B-4 [c] B-4 [m] B-18
Total Volatile Organic Compounds (TVOCs)	New building materials and furnishings Consumable products Maintenance materials Outdoor air	Precise guidance on TVOC concentrations cannot be given	A variety of definitions of TVOC have been employed in the past. Reference B-27 contains a specific definition that reflects recent thinking on the subject. There is insufficient evidence that TVOC measurements can be used to predict health or comfort effects. In addition, odor and irritation responses to organic compounds are highly variable. Furthermore, no single method currently in use measures all organic compounds that may be of interest. Therefore, some investigators have reported the total of all measured VOCs as the SumVOC in order to make explicit that the reported value does not represent the total of all VOCs present. Some of the references included here use this method for presenting VOC measurement results. Setting target concentrations for TVOCs is not recommended. Setting target concentrations for specific VOCs of concern is preferred.	B-9 [m] B-14, 26-28, 35, 37
Volatile Organic Compounds (VOCs) (See Table B-3 for a list of selected compounds)	New building materials and furnishings Consumable products Maintenance materials Outdoor air	Must be determined for each individual compound (See Table B-3 for a list of selected compounds)	Individual volatile organic compounds may be contaminants of concern in the application of the IAQ Procedure. Concentrations of concern range from less than 1 part per billion (ppb) for some very toxic compounds or for compounds having very low odor thresholds up to concentrations several orders of magnitude higher. Not all compounds can be identified, and toxicological data are incomplete for many compounds.	B-22–26, 28, 42, 43, 44 [c] B-9, 10, 21 [m] B-11, 15, 36, 38, 39, 11

**TABLE B-2 Concentration of Interest for Selected Contaminants (Continued)**

(Note: References numbers that are followed by [c] and [m] list the concentrations of interest [c] and measurement methods [m].)  
(Note: The user of any value in this table should take into account the purpose for which it was adopted and the means by which it was developed.)

<sup>a</sup> The US EPA has promulgated a guideline value of 4 pCi/L indoor concentration. This is not a regulatory value but an action level where mitigation is recommended if the value is exceeded in long-term tests.

**Conversion Factors<sup>B-17</sup>**

Parts per million and mass per unit volume:

Measurements of indoor airborne concentrations of substances are generally converted to standard conditions of 77°F (25°C) and 29.92 in. Hg (101.325 kPa) pressure. Vapors or gases are often expressed in parts per million (ppm) by volume or in mass per unit volume. Concentrations in ppm by volume can be converted to mass per unit volume values as follows:

$$\begin{aligned} \text{ppm} \times \text{molecular weight}/24,450 &= \text{mg/L} \\ \text{ppm} \times \text{molecular weight}/0.02445 &= \mu\text{g}/\text{m}^3 \\ \text{ppm} \times \text{molecular weight}/24.45 &= \text{mg}/\text{m}^3 \\ \text{ppm} \times \text{molecular weight} \times 28.3/24,450 &= \text{mg}/\text{ft}^3 \end{aligned}$$

### Guide for Using Table B-3

Table B-3 provides information that may be beneficial for designers who choose to comply with the Indoor Air Quality Procedure of this Standard. The VOCs included in the table were reported in published, peer-reviewed surveys conducted in office buildings and in new and existing residences in North America during the period 1990–2000.<sup>B-42,B-43,B-45</sup> Only those VOCs for which exposure guidelines for the general population have been developed by cognizant authorities are listed in Table B-3.

Reference Exposure Levels (RELs) are guidelines for acute, 8-hour and chronic inhalation exposures developed by California Office of Health Hazard Assessment (OEHHA). Minimal Risk Levels (MRLs) for hazardous substances are guidelines for acute, intermediate and chronic inhalation exposures developed by the Agency for Toxic Substances and Disease Registry (ATSDR). Factors for  $\mu\text{g}/\text{m}^3$  to ppb concentration conversions are shown.

The table does not purport to represent (a) all possible chemicals found in nonindustrial indoor environments and (b) all concentration guidelines, standards, and regulatory limits. Published, peer-reviewed surveys conducted in office buildings and in new and existing residences in North America since 2000 may identify several more compounds, for some of which guidelines may be available from the cognizant authorities described above.

**TABLE B-3 Concentrations of Interest for Selected Volatile Organic Compounds**

Compound	CAS Number	Chemical Class <sup>a</sup>	Conversion Factor: $\mu\text{g}/\text{m}^3$ to ppb <sup>b</sup>	CA OEHHA REL <sup>B-36</sup>			ATSDR MRL <sup>B-46</sup>		
				Acute <sup>c</sup> ( $\mu\text{g}/\text{m}^3$ )	8-hr <sup>d</sup> ( $\mu\text{g}/\text{m}^3$ )	Chronic <sup>e</sup> ( $\mu\text{g}/\text{m}^3$ )	Acute <sup>f</sup> (ppb)	Intermediate <sup>g</sup> (ppb)	Chronic <sup>h</sup> (ppb)
Acetaldehyde	75-07-0	Ald	0.554	470	300	140			
Acrolein	107-02-8	Ald	0.436	2.5	0.7	0.35	3	0.4	
Acrylonitrile	107-13-1	Misc	0.460			5	100		
Benzene	71-43-2	Arom	0.313	1300		60	9	6	3
Bromomethane (Methyl bromide)	74-83-9	Halo	0.258				50	50	5
1,3-Butadiene	106-99-0	Alke	0.452			20			
2-Butanone	78-93-3	Ket	0.339	13,000					
2-Butoxyethanol	111-76-2	Gly	0.207				6000	3000	200
<i>t</i> -Butyl methyl ether (Methyl- <i>t</i> -butyl ether)	1634-04-4	Ethr	0.277			8000	2000	700	700
Carbon disulfide	75-15-0	Misc	0.321	6200		800			300
Carbon tetrachloride	56-23-5	Halo	0.159	1900		40		30	30
Chlorobenzene	108-90-7	ClAro	0.217			1000			
Chloroform	67-66-3	Halo	0.205	150		300	100	50	20
1,4-Dichlorobenzene	106-46-7	ClAro	0.166			800	2000	200	10
1,2-Dichloroethane (Ethylene dichloride)	107-06-2	Halo	0.247						600

**TABLE B-3 Concentrations of Interest for Selected Volatile Organic Compounds (Continued)**

Compound	CAS Number	Chemical Class <sup>a</sup>	Conversion Factor: μg/m <sup>3</sup> to ppb <sup>b</sup>	CA OEHHA REL <sup>B-36</sup>			ATSDR MRL <sup>B-46</sup>		
				Acute <sup>c</sup> (μg/m <sup>3</sup> )	8-hr <sup>d</sup> (μg/m <sup>3</sup> )	Chronic <sup>e</sup> (μg/m <sup>3</sup> )	Acute <sup>f</sup> (ppb)	Intermediate <sup>g</sup> (ppb)	Chronic <sup>h</sup> (ppb)
Dichloromethane (Methylene chloride)	75-09-2	Halo	0.288	14,000		400	600	300	300
1,4-Dioxane	123-91-1	Ethr	0.278	3000		3000	2000	1000	1000
Ethylbenzene	100-41-4	Arom	0.230			2000	10,000	700	300
Ethylene glycol	107-21-1	Gly	0.394			400	788		
Formaldehyde <sup>i</sup>	50-00-0	Ald	0.815	55	9	9	40	30	8
n-Hexane	110-54-3	Alka	0.284			7000	600		
Naphthalene	91-20-3	Arom	0.191			9			0.7
Phenol	108-95-2	Alc	0.260	5800		200			
2-Propanol (Isopropanol)	67-63-0	Alc	0.407	3200					
2-Propanone (Acetone)	67-64-1	Ket	0.421				26,000	13,000	13,000
Styrene	100-42-5	Arom	0.235	21,000		900	2000		200
Tetrachloroethene (Tetrachloroethylene, Perchloroethylene)	127-18-4	Halo	0.147	20,000		35	200		40
Toluene	108-88-3	Arom	0.265	37,000		300	1000		80
1,1,1-Trichloroethane (Methyl chloroform)	71-55-6	Halo	0.183	68,000		1000	2000	700	
Trichloroethene (Trichloroethylene)	79-01-6	Halo	0.186			600	2000	100	
Vinyl chloride	75-01-4	Halo	0.391	180,000			500	30	
Xylene isomers	1330-20-7	Arom	0.230	22,000		700	2000	600	50

<sup>a</sup> Alc = alcohol; Ethr = ether; Gly = glycol ether; Ket = ketone; Ald = aldehyde; Estr = acetates and other esters; Acid = carboxylic acid; Alka = alkane HC; Alke = alkene HC; Cycl = cyclic HC; Terp = terpene HC; Arom = aromatic HC; ClAro = chlorinated aromatic HC; Halo = halogenated aliphatic HC; Misc = miscellaneous category.

<sup>b</sup> Conversion factors from μg/m<sup>3</sup> to ppb.

<sup>c</sup> Exposure averaging time is 1 hour.

<sup>d</sup> Exposure averaging time is 8 hours and which may be repeated.

<sup>e</sup> Designed to address continuous exposures for up to a lifetime: the exposure metric used is the annual average exposure.

<sup>f</sup> Exposure to a chemical for a duration of 14 days or less, as specified in the toxicological profiles.

<sup>g</sup> Exposure to a chemical for a duration of 15–364 days, as specified in the toxicological profiles.

<sup>h</sup> Exposure to a chemical for 365 days or more, as specified in the toxicological profiles.

<sup>i</sup> See also Tables B-1 and B-2 for additional guidance on formaldehyde.

When performing a subjective evaluation, an observer should enter the space in the manner of a normal visitor and should render a judgment of acceptability within 15 seconds. Each observer should make the evaluation independently of other observers and without influence from a panel leader. Users of subjective evaluation methods are cautioned that they only test odor and sensory responses. Some harmful contaminants will not be detected by such tests. Carbon monoxide and radon are two examples of odorless contaminants that pose significant health risks. To evaluate the acceptability of adapted persons (occupants), an observer should spend at least six minutes in the space before rendering a judgment of acceptability.<sup>B-29</sup>

## REFERENCES

- B-1. ACGIH. 2005. *Threshold Limit Values for Chemical Substances and Physical Agents and Biological Exposure Indices*. American Conference of Governmental Industrial Hygienists, 1330 Kemper Meadow Drive, Cincinnati, OH 45240-1634. www.acgih.org.
- B-2. *Maximum Concentrations at the Workplace and Biological Tolerance Values for Working Materials 2000*, Commission for the Investigation of Health Hazards of Chemical Compounds in the Work Area, Federal Republic of Germany.
- B-3. Martin, W., and A.C. Stern. 1974. *The World's Air Quality Standards*, Vol. II. *The Air Quality Management Standards of the United States*, Table 17, pp. 11–38. October 1974 (available from NTIS PB-241-876; National Technical Information Service, 4285 Port Royal Road, Springfield, VA 22161).
- B-4. U.S. Environmental Protection Agency. 2008. *Code of Federal Regulations*, Title 40, Part 50. National Ambient Air Quality Standards. www.epa.gov/air/criteria.html.
- B-5. U.S. Department of Labor, Occupational Safety and Health Administration. *Code of Federal Regulations*, Title 29, Part 1910.1000-1910.1450. www.osha.gov.
- B-6. U.S. Food and Drug Administration. 2004. *Code of Federal Regulations*, Title 21, Part 801.415 (maximum acceptable levels of ozone), April 1. www.gpoaccess.gov/cfr/index.htm/.
- B-7. U.S. Environmental Protection Agency. 1992. *A Citizen's Guide to Radon and Technical Support Document for the Citizen's Guide to Radon*.
- B-8. Health Canada. 1995. *Exposure Guidelines for Residential Indoor Air Quality: A Report of the Federal-Provincial Advisory Committee on Environmental and Occupational Health*. Ottawa: Health Canada. www.hc-sc.gc.ca/heccsesc/air\_quality/pdf/tr-156.pdf.
- B-9. U.S. Environmental Protection Agency. 1990. *Compendium of Methods for Determination of Air Pollutants in Indoor Air*. Document No. PB 90-200-288/AS, available from NTIS, Springfield, VA 22161.
- B-10. American Society of Testing and Materials. *Annual Book of ASTM Standards*, Section 11, Vol. 11.03 *Atmospheric Analysis; Occupational Health and Safety*. ASTM, West Conshohocken, PA.
- B-11. World Health Organization. 2000. *Air Quality Guidelines for Europe, 2nd Edition*. World Health Organization Regional Publications, European Series No. 91. World Health Organization, Regional Office for Europe, Copenhagen, www.euro.who.int/document/e71922.pdf.
- B-12. Commission of the European Communities. 1992. *Report No. 11: Guidelines for Ventilation Requirements in Buildings*. Joint Research Centre, Ispra (Varese), Italy.
- B-13. NIOSH. 2004. *NIOSH Pocket Guide to Chemical Hazards (NPG)*. National Institute for Occupational Safety and Health, February. www.cdc.gov/niosh/npg/npg.html.
- B-14. Shields, H.C., D.M. Fleischer, and C.J. Weschler. 1996. Comparisons among VOCs measured at three types of U.S. commercial buildings with different occupant densities. *Indoor Air* 6(1):2–17.
- B-15. Devos, M. F. Patte, J. Rouault, P. Laffort, and L.J. Van Gemert. 1990. *Standardized Human Olfactory Thresholds*. Oxford University Press, Oxford.
- B-16. California Air Resources Board. 2004. *Indoor Air Quality Guideline No. 1, Formaldehyde in the Home*. August. Sacramento, CA. http://www.arb.ca.gov/research/indoor/formaldGL08-04.pdf.
- B-17. American Society of Testing and Materials. 2004. *Standard Practice for Conversion Units and Factors Relating to Sampling and Analysis of Atmospheres*, D-1914-95(2004)e1. In *Annual Book of ASTM Standards*, 2004; Section Eleven, Water and Environmental Technology, Vol. 11.03. 100 Barr Harbor Drive, West Conshohocken, PA, 19428, www.astm.org.
- B-18. U.S. Environmental Protection Agency. *The Plain English Guide To The Clean Air Act*. EPA Office of Air Quality Planning and Standards. www.epa.gov/oar/oaqps/peg\_cca/pegcaa11.html.
- B-19. U.S. Environmental Protection Agency. 1988. *Health and Environmental Effects Profile for Formaldehyde*. EPA/600/x-85/362. Environmental Criteria and Assessment Office, Office of Health and Environmental Assessment, Office of Research and Development, Cincinnati, OH.
- B-20. U.S. Environmental Protection Agency. *Formaldehyde; Hazard Summary*. Technology Transfer Network, Air Toxics Web site, Office of Air Quality Planning and Standards. www.epa.gov/ttnatw01/hlthef/formalde.html.
- B-21. Hodgson, A.T. 1995. A review and a limited comparison of methods for measuring total volatile organic compounds in indoor air. In *Indoor Air*, Vol. 5, No. 4.
- B-22. Brown, S., M.R. Sim, M.J. Abramson, and C.N. Gray. 1994. Concentrations of volatile organic compounds in indoor air—A review, p. 123–34. In *Indoor Air*, Vol. 4.
- B-23. Daisey, J.M., A.T. Hodgson, W.J. Fisk, M.J. Mendell, and J. Ten Brinks. 1994. Volatile organic compounds in twelve California office buildings: Classes, concentrations, and sources, p. 3557–62. In *Atmospheric Environment*, Vol. 28, No. 22.
- B-24. Nielsen et al. 1998. In H. Levin (Ed.), *Indoor Air Guideline Values for Organic Acids, Phenols, and*

- Glycol Ethers*. Indoor Air Supplement 5/1998. Munksgaard, Copenhagen.
- B-25. Anonymous. 1999. *Jane's Chem-Bio Handbook*. Jane's Information Group. Alexandria, Virginia.
- B-26. Anderson, K., J.V. Bakke, O. Bjørseth, C.-G. Bornehag, G. Clausen, J.K. Honglo, M. Kjellman, S. Kjærgaard, F. Levy, L. Mølhave, S. Skerfving and J. Sundell. 1997. *TVOC and Health in Non-Industrial Indoor Environments*. Report from a Nordic Scientific Consensus Meeting at Långholmen in Stockholm, 1996. In *Indoor Air*, Vol 7:78–91.
- B-27. European Collaborative Action. *Total Volatile Organic Compounds (TVOC) in Indoor Air Quality Investigations*, Report No. 19 (EUR 17675 EN). Joint Research Centre, Environment Institute, European Commission. Ispra, Italy.
- B-28. Wolkoff, P., P.A. Clausen, B. Jensen, G.D. Nielsen and C.K. Wilkins. 1997. Are we measuring the relevant indoor pollutants?, pp. 92–106. In *Indoor Air*, Vol. 7.
- B-29. Gunnarsen, L. and P.O. Fanger. 1992. Adaptation to indoor air pollution, pp. 43–54. In *Environment International*, Vol. 18.
- B-30. National Institutes of Safety and Health (NIOSH). 1991. *Environmental Tobacco Smoke in the Workplace*.
- B-31. California Environmental Protection Agency (CalEPA). 1997. *Health Effects of Exposure to Environmental Tobacco Smoke*, Sept. Available at: [www.oehha.ca.gov/air/environmental\\_tobacco/finalets.html](http://www.oehha.ca.gov/air/environmental_tobacco/finalets.html).
- B-32. ACGIH. 1999. *Bioaerosols: Assessment and Control*. American Conference of Governmental Industrial Hygienists. Cincinnati.
- B-33. Roach, S.A and S.M. Rappoport. 1990. But they are not thresholds: A critical analysis, the documentation of threshold limit values, pp. 727–53. In *American Journal of Industrial Medicine*, Vol. 17.
- B-34. Castleman, B.I and G.E. Ziem. 1988. Corporate influence on threshold limit values, pp. 531–59. In *Am. J. Ind. Med.* Vol. 13.
- B-35. Bluysen et al. 1996. European indoor air quality audit project in 56 office buildings. In *Indoor Air*. Vol. 6.
- B-36. California Environmental Protection Agency, Office of Environmental Health Hazard Assessment. December 18, 2008. *Air Toxics Hot Spots Program Risk Assessment Guidelines. Technical Support Document for the Derivation of Noncancer Reference Exposure Levels*. OEHHA, Sacramento, CA. Available at <http://www.oehha.org/air/allrels.html>.
- B-37. Womble S.E., E.L. Ronca, J.R. Girman, and H.S. Brightman. 1996. Developing baseline information on buildings and indoor air quality (BASE '95), pp. 109–17. In *Proceedings of IAQ 96/Paths to Better Building Environments/Health Symptoms in Building Occupants*, Atlanta, Georgia.
- B-38. Hadwen, G.E., J.F. McCarthy, S.E. Womble, JR Girman, and H.S. Brightman, 1997. Volatile organic compound concentrations in 41 office buildings in the continental United States, pp. 465–70. In J.E. Woods, D.T. Grimsrud, and N. Boschi, (Eds.), *Proceedings: Healthy Buildings/IAQ'97*. Washington, DC: Vol. 2.
- B-39. Apte, M.G. and J.M. Daisey. 1999. VOCs and “sick building syndrome”: Application of a new statistical approach for SBS research to US EPA BASE study data, pp. 117–22. In *Proceedings of Indoor Air 99: The 8th International Conference on Indoor Air Quality and Climate, Edinburgh, Scotland, 8–13 August*. Vol. 1.
- B-40. International Agency for Research on Cancer (IARC). 2004. *Monographs on the Evaluation of Carcinogenic Risks to Humans: Formaldehyde, 2-Butoxyethanol and 1-tert-Butoxy-2-propanol* 88:2–9 (June). [www.iarc.fr/htdocs/announcements/vol88.html](http://www.iarc.fr/htdocs/announcements/vol88.html).
- B-41. California Air Resources Board. 2005. *California Ambient Air Quality Standards*. Sacramento, CA. <http://www.arb.ca.gov/research/aaqs/caaqs/caaqs.htm>.
- B-42. Hodgson, A.T., and H. Levin. 2003. Volatile Organic Compounds in Indoor Air: A Review of Concentrations Measured in North America Since 1990. LBL Report 51715, April 2003. <http://eetd.lbl.gov/ied/pdf/LBNL-51715.pdf>.
- B-43. Hodgson, A.T., and H. Levin. 2003. Classification of Measured Indoor Volatile Organic Compounds Based on Noncancer Health and Comfort Considerations. LBL Report 53308. Lawrence Berkeley National Laboratory, September 2003. <http://eetd.lbl.gov/ied/pdf/LBNL-53308.pdf>.
- B-44. European Commission. 2004. *Critical Appraisal of the Setting and Implementation of Indoor Exposure Limits in the EU (THE INDEX Project): Summary of Recommendations and Management Options*. December 2004. Joint Research Centre, Institute for Health and Consumer Protection, Physical and Chemical Exposure Unit, Ispra, Italy. Available at [http://ec.europa.eu/health/index\\_en.htm](http://ec.europa.eu/health/index_en.htm).
- B-45. Levin, H. and A. T. Hodgson. 2006. VOC Concentrations of Interest in North American Offices and Homes. *Proceedings Healthy Buildings 2006*, Lisbon, Portugal, 4-8 June, 2006, Vol. I, pp. 233-238.
- B-46. U.S. Department of Health and Human Services, Agency for Toxic Substances and Disease Registry (ATSDR), Jan. 14, 2009. *Minimal Risk Levels (MRLs)*. Accessible at <http://www.atsdr.cdc.gov/mrls/>
- B-47. California Air Resources Board. 2008; *Airborne Toxic Control Measure to Reduce Formaldehyde Emissions from Composite Wood Products*. California Code of Regulations, Title 17, Sections 93120-93120.12. Also available at <http://www.arb.ca.gov/toxics/compwood/compwood.htm>.
- B-48. FEMA Procurement Specification, Release Number HQ-08-056, April 11, 2008. Available at: <http://www.fema.gov/news/newsrelease.fema?id=43180>.

(This appendix is not part of this standard. It is merely informative and does not contain requirements necessary for conformance to the standard. It has not been processed according to the ANSI requirements for a standard and may contain material that has not been subject to public review or a consensus process. Unresolved objectors on informative material are not offered the right to appeal at ASHRAE or ANSI.)

### INFORMATIVE APPENDIX C RATIONALE FOR MINIMUM PHYSIOLOGICAL REQUIREMENTS FOR RESPIRATION AIR BASED ON CO<sub>2</sub> CONCENTRATION

Oxygen is necessary for metabolism of food to sustain life. Carbon and hydrogen in foods are oxidized to CO<sub>2</sub> and H<sub>2</sub>O, which are eliminated by the body as waste products. Foods can be classified as carbohydrates, fats, and proteins, and the ratio of carbon to hydrogen in each is somewhat different. The respiratory quotient (*RQ*) is the volumetric ratio of carbon dioxide produced to oxygen consumed. It varies from 0.71 for a diet of 100% fat to 0.8 for a diet of 100% protein and 1.00 for a diet of 100% carbohydrates (see Reference C-1). A value of *RQ* = 0.83 applies to a normal diet mix of fat, carbohydrate, and protein.

The rate at which oxygen is consumed and carbon dioxide is generated depends on physical activity. These relationships are shown in Figure C-2 (see Reference C-2). The breathing rate is shown also. A simple mass balance equation gives the outdoor airflow rate needed to maintain the steady-state CO<sub>2</sub> concentration below a given limit.

$$V_o = N / (C_s - C_o) \quad (C-1)$$

where

- $V_o$  = outdoor airflow rate per person
- $V_e$  = breathing rate
- $N$  = CO<sub>2</sub> generation rate per person
- $C_e$  = CO<sub>2</sub> concentration in exhaled breath
- $C_s$  = CO<sub>2</sub> concentration in the space
- $C_o$  = CO<sub>2</sub> concentration in outdoor air

For example, at an activity level of 1.2 met units (1.0 met = 18.4 Btu/h·ft<sup>2</sup>), corresponding to sedentary persons, the CO<sub>2</sub> generation rate is 0.31 L/min. Laboratory and field studies have shown that with sedentary persons about 15 cfm (7.5 L/s) per person of outdoor air will dilute odors from human bioeffluents to levels that will satisfy a substantial majority (about 80%) of unadapted persons (visitors) to a space.<sup>C-3,C-4,C-5,C-6,C-7</sup> If the ventilation rate is to be held to 15 cfm (7.5 L/s) per person, the resulting steady-state CO<sub>2</sub> concentration relative to that in the outdoor air is

$$\begin{aligned} C_s - C_o &= N / V_o \\ &= 0.31 / (7.5 \times 60 \text{ s/min}) \\ &= 0.000689 \text{ L of CO}_2 \text{ per L of air} \\ &\approx 700 \text{ ppm} \end{aligned}$$

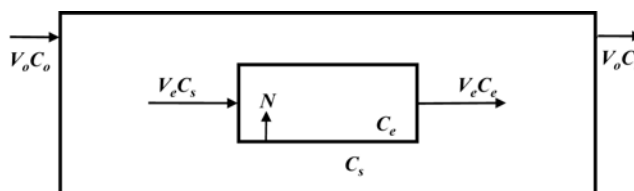

Figure C-1 Two chamber model.

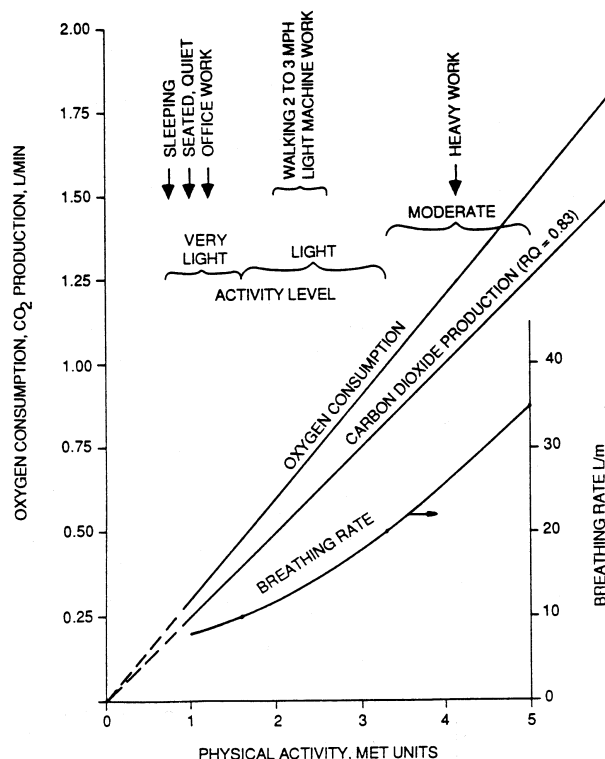

Figure C-2 Metabolic data.

Thus, maintaining a steady-state CO<sub>2</sub> concentration in a space no greater than about 700 ppm above outdoor air levels will indicate that a substantial majority of visitors entering a space will be satisfied with respect to human bioeffluents (body odor). A more detailed discussion of this relationship between CO<sub>2</sub> concentrations and the perception of bioeffluents, as well as the use of indoor CO<sub>2</sub> to estimate building ventilation rates, is contained in ASTM Standard D6245.<sup>C-8</sup>

CO<sub>2</sub> concentrations in acceptable outdoor air typically range from 300 to 500 ppm. High CO<sub>2</sub> concentrations in the outdoor air can be an indicator of combustion and/or other contaminant sources.

Figure C-3 shows the outdoor airflow rate required as a function of physical activity and steady-state room concentration. If the activity level is greater than 1.2 met, the required ventilation must be increased to maintain the same carbon dioxide level.

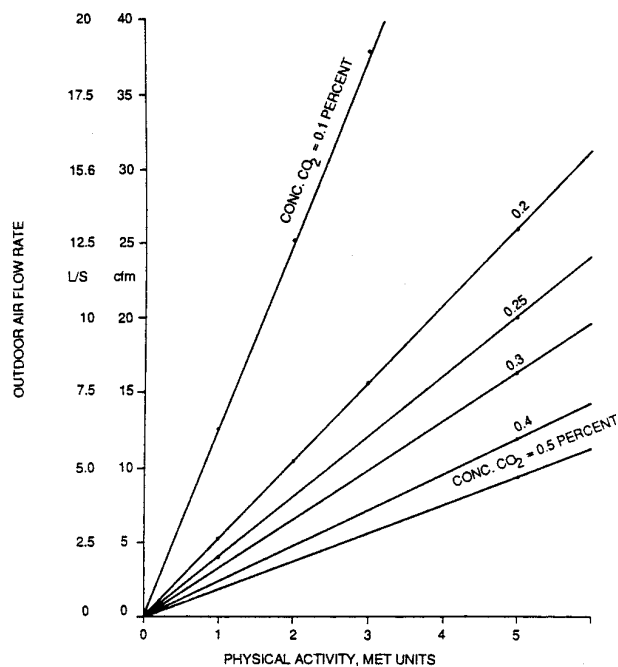

Figure C-3 Ventilation requirements.

Also the decrease in oxygen content of the room air can be found from Equation C-1 when oxygen concentration is substituted for carbon dioxide concentration.

$$C_o - C_s = N/V_o \quad (C-2)$$

The term  $N$  now has a negative value with respect to its use in Equation C-1 since oxygen is consumed rather than generated.

$$C_s = C_o - N/V_o \quad (C-3)$$

The oxygen consumption rate is 0.36 L/min when the activity level is 1.2 met. For ventilation at a rate of 15 cfm (429 L/m) and an activity level of 1.2 met units, the room oxygen level will be reduced from an outdoor concentration of

20.95% to 20.85%, a percent change of 0.48% [(20.95 – 20.85)/20.95]. Unlike oxygen, carbon dioxide is generated as a result of activity. At 1.2 met, the carbon dioxide indoors is raised from the outdoor background of 0.03% to 0.1%, a percent change of 230%. Thus, measuring the increase of carbon dioxide is clearly more significant than measuring the decrease of oxygen.

## REFERENCES

- C-1. McHattie, L.A. 1960. Graphic visualization of the relations of metabolic fuels: Heat: O<sub>2</sub>, CO<sub>2</sub>, H<sub>2</sub>O: Urine N., pp. 677–83. In *J. Applied Physiology* Vol. 15, No. 4.
- C-2. *ASHRAE Handbook—2005 Fundamentals*, Chapter 8. 2005. American Society of Heating, Refrigerating and Air-Conditioning Engineers, Inc., Atlanta, GA 30329.
- C-3. Berg-Munch, B., G.H. Clausen, and P.O. Fanger. 1986. Ventilation requirements for the control of body odor in spaces occupied by women, pp. 195–200. In *Environ. Int.* Vol. 12.
- C-4. Cain, W.S., et al. 1983. Ventilation requirements in buildings—I. Control of occupancy odor and tobacco smoke odor, pp. 1183–97. In *Atmos. Environ.* Vol. 17, No. 6.
- C-5. Fanger, P.O., and B. Berg-Munch. 1983. Ventilation and body odor, pp. 45–50. In *Proceedings of an Engineering Foundation Conference on Management of Atmospheres in Tightly Enclosed Spaces*. Atlanta: American Society of Heating, Refrigerating and Air-Conditioning Engineers, Inc.
- C-6. Iwashita, G., K. Kimura, et al. 1989. Pilot study on addition of old units for perceived air pollution sources, pp. 321–24. In *Proceedings of SHASE Annual Meeting*. Tokyo: Society of Heating, Air-Conditioning and Sanitary Engineers of Japan.
- C-7. Yaglou, C.P., E.C. Riley, and D.I. Coggins. 1936. Ventilation requirements, pp. 133–62. In *ASHRAE Transactions* Vol. 42.
- C-8. ASTM. 1998. *ATSM Standard D6245, Standard Guide for Using Indoor Carbon Dioxide Concentrations to Evaluate Indoor Air Quality and Ventilation*. Philadelphia: American Society for Testing and Materials, D6245-98.



**(This appendix is not part of this standard. It is merely informative and does not contain requirements necessary for conformance to the standard. It has not been processed according to the ANSI requirements for a standard and may contain material that has not been subject to public review or a consensus process. Unresolved objectors on informative material are not offered the right to appeal at ASHRAE or ANSI.)**

**INFORMATIVE APPENDIX D  
ACCEPTABLE MASS BALANCE EQUATIONS  
FOR USE WITH THE IAQ PROCEDURE**

When applying the Indoor Air Quality (IAQ) Procedure from Section 6.3, mass balance analysis may be employed to determine outdoor air ventilation requirements to control

indoor contaminant levels. Table D-1 presents mass balance equations for analysis of single-zone systems. Figures D-1 and D-2 show representative single-zone systems. A filter may be located in the recirculated airstream (location A) or in the supply (mixed) airstream (location B).

Variable-air-volume (VAV) single-zone systems reduce the circulation rate when the thermal load is lower than the design load. This is accounted for by a flow reduction fraction ( $F_r$ ).

A mass balance equation for the contaminant-of-concern may be written and used to determine the required outdoor airflow or the breathing zone contaminant concentration for the various system arrangements. Six permutations for air-handling and single-zone air distribution systems are described in Table D-1. The mass balance equations for computing the required outdoor airflow and the breathing-zone contaminant

**TABLE D-1 Required Zone Outdoor Airflow or Space Breathing Zone Contaminant Concentration with Recirculation and Filtration for Single-Zone Systems**

Required Recirculation Rate			Required Zone Outdoor Airflow ( $V_{oz}$ in Section 6)	Space Breathing Zone Contaminant Concentration
Filter Location	Flow	Outdoor Airflow		
None	VAV	100%	$V_{oz} = \frac{N}{E_z F_r (C_{bz} - C_o)}$	$C_{bz} = C_o + \frac{N}{E_z F_r V_{oz}}$
A	Constant	Constant	$V_{oz} = \frac{N - E_z R V_r E_f C_{bz}}{E_z (C_{bz} - C_o)}$	$C_{bz} = \frac{N + E_z V_{oz} C_o}{E_z (V_{oz} + R V_r E_f)}$
A	VAV	Constant	$V_{oz} = \frac{N - E_z F_r R V_r E_f C_{bz}}{E_z (C_{bz} - C_o)}$	$C_{bz} = \frac{N + E_z V_{oz} C_o}{E_z (V_{oz} + F_r R V_r E_f)}$
B	Constant	Constant	$V_{oz} = \frac{N - E_z R V_r E_f C_{bz}}{E_z [C_{bz} - (1 - E_f)(C_o)]}$	$C_{bz} = \frac{N + E_z V_{oz} (1 - E_f) C_o}{E_z (V_{oz} + R V_r E_f)}$
B	VAV	100%	$V_{oz} = \frac{N}{E_z F_r [C_{bz} - (1 - E_f)(C_o)]}$	$C_{bz} = \frac{N + E_z F_r V_{oz} (1 - E_f) C_o}{E_z F_r V_{oz}}$
B	VAV	Constant	$V_{oz} = \frac{N - E_z F_r R V_r E_f C_{bz}}{E_z [C_{bz} - (1 - E_f)(C_o)]}$	$C_{bz} = \frac{N + E_z V_{oz} (1 - E_f) C_o}{E_z (V_{oz} + F_r R V_r E_f)}$

Symbol or Subscript	Definition
$A, B$	filter location
$V$	volumetric flow
$C$	contaminant concentration
$E_z$	zone air distribution effectiveness
$E_f$	filter efficiency
$F_r$	design flow reduction fraction factor
$N$	contaminant generation rate
$R$	recirculation flow factor
Subscript: $o$	outdoor
Subscript: $r$	return
Subscript: $b$	breathing
Subscript: $z$	zone

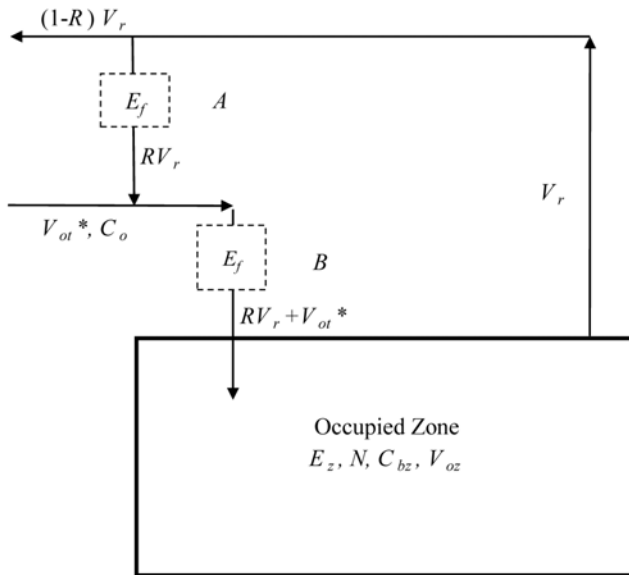

**Figure D-1 Ventilation system schematic—constant volume system with no infiltration/exfiltration. ( $*V_{ot} = V_{oz}$  for single-zone systems.)**

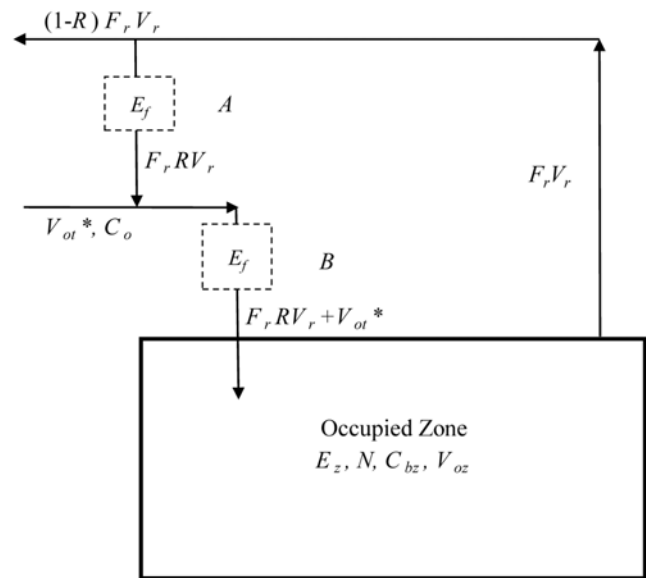

**Figure D-2 Ventilation system schematic—variable air volume system with no infiltration/exfiltration. ( $*V_{ot} = V_{oz}$  for single-zone systems.)**

concentration at steady-state conditions for each single-zone system are presented in Table D-1.

If the allowable breathing zone contaminate concentration is specified, the equations in Table D-1 may be solved for the zone outdoor airflow rate ( $V_{oz}$ ). When the zone outdoor airflow rate is specified, the equations may be solved for the resulting breathing zone contaminant concentration.

While the calculation methods in this appendix are based on single-zone systems and steady-state analysis, calculation

methods that account for multiple-zone and transient effects are also available.<sup>D-1</sup>

## REFERENCE

D-1 Dols, W.S., and G.N. Walton. 2002. CONTAMW 2.0 User Manual. National Institute of Standards and Technology, NISTIR 6921.

**This appendix is not part of this standard. It is merely informative and does not contain requirements necessary for conformance to the standard. It has not been processed according to the ANSI requirements for a standard and may contain material that has not been subject to public review or a consensus process. Unresolved objectors on informative material are not offered the right to appeal at ASHRAE or ANSI.)**

**INFORMATIVE APPENDIX E  
INFORMATION ON SELECTED  
NATIONAL STANDARDS AND GUIDELINES FOR PM10, PM 2.5 AND OZONE**

**TABLE E-1 Information Sources for Identifying Non-Complying Locations  
(Information Current as of June 20, 2008)**

Country	PM10	PM2.5	Ozone
United States	Find non-attainment areas at: <a href="http://epa.gov/air/airpollutants.html">http://epa.gov/air/airpollutants.html</a>	Find non-attainment areas at: <a href="http://epa.gov/air/airpollutants.html">http://epa.gov/air/airpollutants.html</a>	<b>ASHRAE 62.1-2010 air cleaning requirement:</b> See Table E-2 for a list of U.S. locations exceeding the 0.107 level as of 06/20/08
Canada	National Building Code of Canada 2010—Part 6, HVAC  <a href="http://www.nationalcodes.ca">www.nationalcodes.ca</a>	National Building Code of Canada 2010—Part 6, HVAC  <a href="http://www.nationalcodes.ca">www.nationalcodes.ca</a>	National Building Code of Canada 2010—Part 6, HVAC  <a href="http://www.nationalcodes.ca">www.nationalcodes.ca</a>

**TABLE E-2 United States Locations Exceeding Design Value of 0.107 ppm for Ozone  
(Locations as of June 20, 2008)**

State Name	County Name
California	Riverside
California	Kern
California	Los Angeles
California	San Bernardino

*Note:* Design values for locations in the United States can be found at [www.epa.gov/airtrends](http://www.epa.gov/airtrends) and by clicking at the Design Values tab. At the time of publication, this information could be found directly at [http://www.epa.gov/air/airtrends/pdfs/dv\\_ozone\\_2004\\_2006.xls](http://www.epa.gov/air/airtrends/pdfs/dv_ozone_2004_2006.xls), column N of the Appendix tab.

(This appendix is not part of this standard. It is merely informative and does not contain requirements necessary for conformance to the standard. It has not been processed according to the ANSI requirements for a standard and may contain material that has not been subject to public review or a consensus process. Unresolved objectors on informative material are not offered the right to appeal at ASHRAE or ANSI.)

## INFORMATIVE APPENDIX F SEPARATION OF EXHAUST OUTLETS AND OUTDOOR AIR INTAKES

### F1. GENERAL

Exhaust air and vent outlets as defined in Table 5-1 shall be located no closer to outdoor air intakes, and operable windows, skylights, and doors, both those on the subject property and those on adjacent properties, than the minimum separation distance ( $L$ ) specified in this section. The distance ( $L$ ) is defined as the shortest “stretched string” distance measured from the closest point of the outlet opening to the closest point of the outdoor air intake opening or operable window, skylight, or door opening, along a trajectory as if a string were stretched between them.

### F2. APPLICATION

Exhaust outlets and outdoor air intakes or other openings shall be separated in accordance with the following.

**Exception:** Laboratory fume hood exhaust air outlets shall be in compliance with NFPA 45-2004 and ANSI/AIHA Z9.5-2003.

**F2.1 Outdoor Air Intakes.** Minimum separation distance between exhaust air/vent outlets as defined in Table 5-1 and outdoor air intakes to mechanical ventilation systems or operable windows, skylights, and doors that are required as part of natural ventilation systems shall be equal to distance ( $L$ ) determined in accordance with Section F3.

**Exception:** Separation distances do not apply when exhaust and outdoor air intake systems do not operate simultaneously.

**F2.2 Other Building Openings.** Minimum separation distance between building exhaust air/vent outlets as defined in Table 5-1 and operable openings to occupiable spaces shall be half of the distance ( $L$ ) determined in accordance with Section F3. Minimum separation distance between high odor intensity or noxious or dangerous exhaust air/vent outlets and operable openings to occupiable spaces shall be equal to the distance ( $L$ ) determined in accordance with Section F3.

**F2.3 Additional Limitations for Noxious or Dangerous Air.** Minimum separation distance between exhausts located less than 65 ft (20 m) vertically below outdoor air intakes or operable windows and doors shall be equal to a horizontal separation only as determined in accordance with Section F3; no credit may be taken for any vertical separation.

**TABLE F-1 Minimum Separation Distance**

Exhaust Air Class (See Section 5.16)	Separation Distance, $L$ , ft (m)
Significant contaminant or odor intensity (Class 3)	15 (5)
Noxious or dangerous particles (Class 4)	30 (10)

**TABLE F-2 Minimum Dilution Factors**

Exhaust Air Class (See Section 5.16)	Dilution Factor, $DF$
Significant contaminant or odor intensity (Class 3)	15
Noxious or dangerous particles (Class 4)	50*

\*Does not apply to fume hood exhaust. See Section F2.

**F2.4 Equipment Wells.** Exhaust air outlets that terminate in an equipment well that also encloses an outdoor air intake shall meet the separation requirements of this section and, in addition, shall either

- terminate at or above the highest enclosing wall and discharge air upward at a velocity exceeding 1000 fpm (5 m/s) or
- terminate 3 ft (1 m) above the highest enclosing wall (with no minimum velocity).

**Exception:** Low contaminant or intensity air.

For the purpose of this section, an equipment well is an area (typically on the roof) enclosed on three or four sides by walls that are less than 75% free area, and the lesser of the length and width of the enclosure is less than three times the average height of the walls. The free area of the wall is the ratio of area of the openings through the wall, such as openings between louver blades and undercuts, divided by the gross area (length times height) of the wall.

**F2.5 Property Lines.** Minimum separation distance between exhaust air/vent outlets and property lines shall be half of the distance ( $L$ ) determined in accordance with Section F3. For significant contaminant or odor intensity exhaust air, where the property line abuts a street or other public way, no minimum separation is required if exhaust termination is 10 ft (3 m) above grade.

### F3. DETERMINING DISTANCE $L$

Separation distance ( $L$ ) shall be determined using any of the following approaches:

- Use the values of  $L$  in Table F-1.
- Calculate  $L$  in accordance with Equation F-1 (a or b).
- Determine  $L$  using any calculation or test procedure approved by the authority having jurisdiction that shows that the proposed design will result in equivalent or greater dilution factors than those specified in Table F-2.

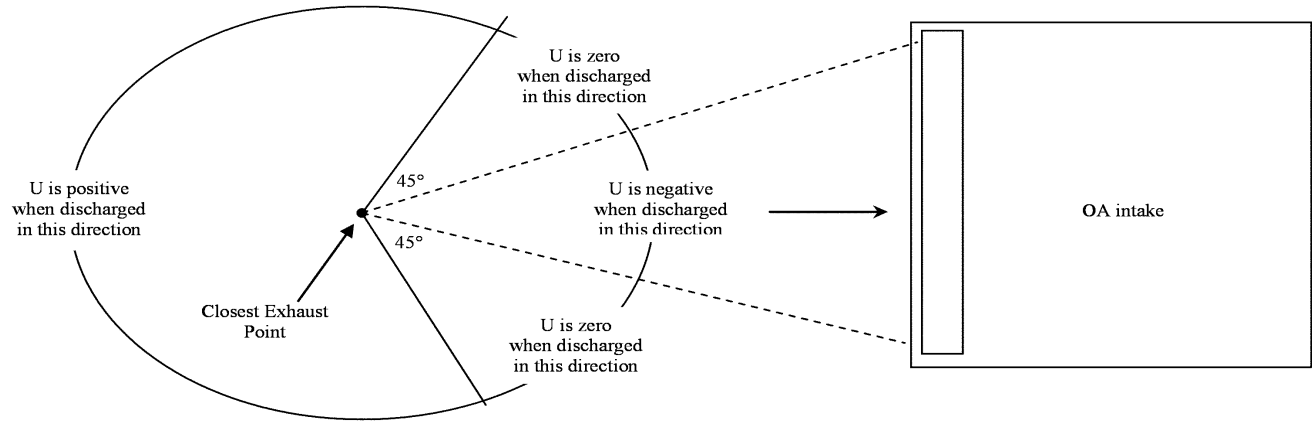

**Figure F-1 Exhaust air discharge velocity (U).**

$$L = 0.09 \cdot \sqrt{Q} \cdot (\sqrt{DF} - U/400) \text{ in feet (I-P)} \quad (\text{F-1a})$$

$$L = 0.04 \cdot \sqrt{Q} \cdot (\sqrt{DF} - U/2) \text{ in meters (SI)} \quad (\text{F-1b})$$

where

$Q$  = exhaust air volume, cfm (L/s). For gravity vents, such as plumbing vents, use an exhaust rate of 150 cfm (75 L/s). For flue vents from fuel-burning appliances, assume a value of 250 cfm per million Btu/h (0.43 L/s per kW) of combustion input (or obtain actual rates from the combustion appliance manufacturer.

$DF$  = dilution factor, which is the ratio of outside air to entrained exhaust air in the outside air intake. The minimum dilution factor shall be determined as a function of exhaust air class in Table F-2.

For exhaust air composed of more than one class of air, the dilution factor shall be determined by averaging the dilution factors by the volume fraction of each class:

$$DF = \frac{\sum (DF_i \cdot Q_i)}{\sum Q_i}$$

where

$DF_i$  = dilution factor from Table F-2 for class  $i$  air and  $Q_i$  is the volumetric flow rate of class  $i$  air in the exhaust airstream.

$U$  = exhaust air discharge velocity, fpm (m/s). As shown in Figure F-1,  $U$  shall have a positive value when the exhaust is directed away from the outside air intake at an angle that is greater than  $45^\circ$  from the direction of a line drawn from the closest exhaust point the edge of the intake;  $U$  shall have a negative value when the exhaust is directed toward the intake bounded by lines drawn from the closest exhaust point the edge of the intake; and  $U$  shall be set to zero for other exhaust air directions regardless of actual velocity.  $U$  shall be set to 0 in Equation F-1 for vents from gravity (atmospheric) fuel-fired appliances, plumbing vents, and other nonpowered exhausts, or if the exhaust discharge is covered by a cap or other device that dissipates the exhaust airstream. For hot gas exhausts such as combustion products, an effective additional 500 fpm (2.5 m/s) upward velocity shall be added to the actual discharge velocity if the exhaust stream is aimed directly upward and unimpeded by devices such as flue caps or louvers.

(This appendix is not part of this standard. It is merely informative and does not contain requirements necessary for conformance to the standard. It has not been processed according to the ANSI requirements for a standard and may contain material that has not been subject to public review or a consensus process. Unresolved objectors on informative material are not offered the right to appeal at ASHRAE or ANSI.)

## INFORMATIVE APPENDIX G APPLICATION AND COMPLIANCE

This appendix contains application and compliance suggestions that are intended to assist users and enforcement agencies in applying this standard.

For the most part, ANSI/ASHRAE Standard 62.1-2010 is specifically written for new buildings because some of its requirements assume that other requirements within the standard have been met. In the case of existing buildings, retroactive application and compliance with all the requirements of this standard may not be practical. However, the principles established in this standard may be applied to most existing commercial and institutional buildings. Some existing buildings may achieve acceptable IAQ despite not meeting the requirements of Standard 62.1-2010 due to, for example, good maintenance and capital improvement procedures, building materials that, by virtue of their age, have very low contaminant emission rates, and many other factors.

### G1. APPLICATION

**G1.1 New Buildings.** All sections and normative appendices should apply to new buildings falling within the scope of this standard.

**G1.2 Existing Buildings.** The standard should be applied to existing buildings at least in the following circumstances:

**G1.2.1 Additions to Existing Buildings.** All additions to existing buildings should meet the requirements of this standard as if the addition were a new building. An exception may be made when an existing ventilation system is extended to serve the addition. In this case, the existing system components, such as fans and cooling and heating equipment, need not meet the requirements of this standard. However, the extended existing system should remain in compliance with ventilation codes and standards that were in effect at the time it was permitted for construction.

**G1.2.2 Repairs.** Repairing (making operational) existing equipment or other building components does not require the building or any of its components to retroactively comply with this standard.

**G1.2.3 Replacement.** Any component of a building that is removed and replaced should meet the applicable requirements of Section 5, Systems and Equipment, of this standard for that component. An exception may be made in cases when replacing a component of like size and kind, provided all requirements of codes and standards used at the time of original system design and installation are met. For example, replacement of an air-conditioning unit with one of similar capacity would not require retroactive compliance with ven-

tilation rates and other requirements of this standard. Unaltered components do not need to be retroactively brought into compliance except when there are substantial alterations (as defined below).

**G1.2.4 Substantial Alterations.** If a building is substantially altered, the requirements of this standard should be met as if the building were new. A building would be considered substantially altered if the cost of the revisions exceeds 50% of the building's fair market value, excluding the cost of compliance with this standard.

**G1.2.5 Change in Use.** If the space application category as listed in Table 6-1 changes, such as from office to retail, the minimum ventilation rates required by Section 6, "Procedures," should be met for that space.

## G2. COMPLIANCE

Demonstrating that acceptable IAQ has been achieved, such as by measuring contaminant concentrations or surveying occupants, would not be required by this standard except where required by the IAQ Procedure.

---

The following section provides suggested model code language.

### APPLICATION AND COMPLIANCE

#### Application

*New Buildings.* All sections and normative appendices apply to new buildings falling within the scope of this standard.

#### Existing Buildings

*Additions to Existing Buildings.* All additions to existing buildings within the scope of this standard shall meet the requirements of all sections and normative appendices.

**Exception:** When an existing ventilation system is extended to serve an addition, the existing system components, such as fans and cooling and heating equipment, need not meet the requirements of this standard. However, the extended existing system must remain in compliance with ventilation codes and standards that were in effect at the time it was permitted for construction.

**Repairs.** Repairing (making operational) existing equipment or other building components shall be allowed without requiring the building or any of its components to comply with this standard.

**Replacement.** Any component of a building that is removed and replaced shall meet the applicable requirements of Section 5, "Systems and Equipment," of this standard for that component. Unaltered components are not required to be brought into compliance except as required due to a change in use.

**Exception:** Replacement of a building component or individual piece of equipment with a component of like size and kind, provided that all requirements of codes effective at the time of original system design and installation are met. For example, replacement of an air-conditioning unit with one of similar capacity would not

*require that the ventilation rate requirements and other requirements of this standard be met.*

**Substantial Alterations.** *If a building is substantially altered, all sections and normative appendices of this standard shall be met as if the building were new. A building shall be considered substantially altered if the cost of the revisions exceeds 50% of the building's fair market value, excluding the cost of compliance with all sections and normative appendices of this standard.*

**Change in Use.** *If the space application category as listed in Table 2 changes, such as from office to retail, the minimum ventilation rates required by Section 6, "Procedures," shall be met for that space.*

### **Compliance**

*Demonstrating that acceptable IAQ has been achieved, such as by measuring contaminant concentrations or surveying occupants, is not required by this standard except where required by the IAQ Procedure.*

**(This appendix is not part of this standard. It is merely informative and does not contain requirements necessary for conformance to the standard. It has not been processed according to the ANSI requirements for a standard and may contain material that has not been subject to public review or a consensus process. Unresolved objectors on informative material are not offered the right to appeal at ASHRAE or ANSI.)**

**INFORMATIVE APPENDIX H  
DOCUMENTATION**

This appendix summarizes the requirements for documentation contained in the body of the standard using a series of templates that summarizes the design criteria used and assumptions made to comply with this standard. One way to comply with the documentation requirements of the standard is to complete these templates as appropriate during the project design process.

**Outdoor Air Quality**

Section 4.3 of this standard requires an investigation of the outdoor air quality in the vicinity of the project site. This template offers a means of documenting the results of both the regional and local investigations and the conclusions reached concerning the acceptability of the outdoor air quality for indoor ventilation.

**TABLE H-1**

<b>Regional Outdoor Air Quality Pollutants</b>	<b>Attainment or Nonattainment According to the U.S. Environmental Protection Agency</b>	
Particulates (PM 2.5)	(Yes/No)	
Particulates (PM 10)	(Yes/No)	
Carbon monoxide—1 hour/8 hours	(Yes/No)	
Ozone	(Yes/No)	
Nitrogen dioxide	(Yes/No)	
Lead	(Yes/No)	
Sulfur Dioxide	(Yes/No)	
<b>Local Outdoor Air Quality Survey</b>	<b>Date:</b>	<b>Time:</b>
a) Area surveyed	(Brief description of the site)	
b) Nearby facilities	(Brief description type of facilities—industrial, commercial, hospitality, etc.)	
c) Odors or irritants	(List and describe)	
d) Visible plumes	(List and describe)	
e) Nearby sources of vehicle exhaust	(List and describe)	
f) Prevailing winds	(Direction)	
g) Other observations		
Conclusions	(Remarks concerning the acceptability of the outdoor air quality)	



### Building Ventilation Design Criteria

This template provides a means of documenting significant design criteria for the overall building. Only the last column, in accordance with Section 5.1.3, is specifically required by the standard. The other columns are motivated by the general documentation requirement described in Section 6.6.

**TABLE H-2**

Building Ventilation Design Criteria						
Total Building Outdoor Air Intake	Total Building Exhaust Air (see Section 5.9.2)	Outdoor Air Cleaning Required (See Section 6.2.1)		Occupied Space Relative Humidity (Choose One Criterion per Section 5.9.1)		Air Balancing (See Section 5.1.3)
		Particulate Matter	Ozone	Peak Outdoor DP at Peak Indoor Latent Load	Lowest Space SHR at Concurrent Outdoor Condition	
(cfm)	(cfm)	(Yes/No)	(Yes/No)	(% RH based on equipment selection)	(% RH based on equipment selection)	(NEBB, AABC, etc.)

### Ventilation Rate Procedure

Section 6.2 permits the use of this prescription-based procedure to design ventilation systems. This template documents the assumptions made when using this procedure as required by Sections 5.16.4 and 6.6.

**TABLE H-3**

Space Identification	Space Type	Occupant Density	Rate/Person	Rate/SF	Zone Air Distribution Effectiveness	System Ventilation Efficiency	Class of Air
(List number or name of each ventilation zone, such as office number or name, retail space name, classroom number)	(List occupancy category of the space from Table 6-1 such as office space, retail sales, classroom age 5–8, etc.)	(People/ft <sup>2</sup> or m <sup>2</sup> )	(cfm or L/s)	(cfm or L/s)	(Table 6-2)	(Table 6-3 or Appendix A)	(Tables 5-2 or 6-1; include justification for classification if not in these tables)

## IAQ Procedure

Section 6.3 permits the use of this performance-based procedure to design ventilation systems. This template documents the design criteria and assumptions made when using this procedure and justification of the design approach, as required by Section 6.3.2.

**TABLE H-4**

Contaminant of Concern	Contaminant Source	Contaminant Strength	IAQ Procedure Assumptions			Perceived IAQ	Design Approach
			Contaminant Target Concentration				
			Limit	Exposure Period	Cognizant Authority Reference		
(Identify and list)	(Identify and list)	(Determine and list)	(List)	(List)	(List)	(Percentage of satisfied building occupants)	(Select from Section 6.3.4 and include justification)

**(This appendix is not part of this standard. It is merely informative and does not contain requirements necessary for conformance to the standard. It has not been processed according to the ANSI requirements for a standard and may contain material that has not been subject to public review or a consensus process. Unresolved objectors on informative material are not offered the right to appeal at ASHRAE or ANSI.)**

## INFORMATIVE APPENDIX I NATIONAL AMBIENT AIR QUALITY STANDARDS

For locations within the United States, the following table shows the ambient air quality standards that determine the regional air quality status of “attainment” or “non-attainment” for the building location.

**TABLE I-1 National Ambient Air Quality Standards (NAAQS)<sup>1</sup>**

Pollutant	Primary Stds.	Averaging Times	Secondary Stds.
Carbon Monoxide	9 ppm (10 mg/m <sup>3</sup> )	8-hour <sup>(1)</sup>	None
	35 ppm (40 mg/m <sup>3</sup> )	1-hour <sup>(1)</sup>	None
Lead	1.5 µg/m <sup>3</sup>	Quarterly Average	Same as Primary
Nitrogen Dioxide	0.053 ppm (100 µg/m <sup>3</sup> )	Annual (Arithmetic Mean)	Same as Primary
Particulate Matter (PM <sub>10</sub> )	Revoked <sup>(2)</sup>	Annual <sup>(2)</sup> (Arith. Mean)	
	150 µg/m <sup>3</sup>	24-hour <sup>(3)</sup>	
Particulate Matter (PM <sub>2.5</sub> )	15.0 µg/m <sup>3</sup>	Annual <sup>(4)</sup> (Arith. Mean)	Same as Primary
	35 µg/m <sup>3</sup>	24-hour <sup>(5)</sup>	
Ozone	0.08 ppm	8-hour <sup>(6)</sup>	Same as Primary
	0.12 ppm	1-hour <sup>(7)</sup> (Applies only in limited areas)	Same as Primary
Sulfur Oxides	0.03 ppm	Annual (Arith. Mean)	—
	0.14 ppm	24-hour <sup>(1)</sup>	—
	—	3-hour <sup>(1)</sup>	0.5 ppm (1300 µg/m <sup>3</sup> )

<sup>(1)</sup> Not to be exceeded more than once per year.

<sup>(2)</sup> Due to a lack of evidence linking health problems to long-term exposure to coarse particle pollution, the agency revoked the annual PM<sub>10</sub> standard in 2006 (effective December 17, 2006).

<sup>(3)</sup> Not to be exceeded more than once per year on average over three years.

<sup>(4)</sup> To attain this standard, the three-year average of the weighted annual mean PM<sub>2.5</sub> concentrations from single or multiple community-oriented monitors must not exceed 15.0 µg/m<sup>3</sup>.

<sup>(5)</sup> To attain this standard, the three-year average of the 98th percentile of 24-hour concentrations at each population-oriented monitor within an area must not exceed 35 µg/m<sup>3</sup> (effective December 17, 2006).

<sup>(6)</sup> To attain this standard, the three-year average of the fourth-highest daily maximum 8-hour average ozone concentrations measured at each monitor within an area over each year must not exceed 0.08 ppm.

<sup>(7)</sup> (a) The standard is attained when the expected number of days per calendar year with maximum hourly average concentrations above 0.12 ppm is < 1, as determined by Appendix H. (b) As of June 15, 2005, the EPA revoked the 1-hour ozone standard in all areas except the fourteen 8-hour ozone nonattainment Early Action Compact (EAC) areas.

**(This appendix is not part of this standard. It is merely informative and does not contain requirements necessary for conformance to the standard. It has not been processed according to the ANSI requirements for a standard and may contain material that has not been subject to public review or a consensus process. Unresolved objectors on informative material are not offered the right to appeal at ASHRAE or ANSI.)**

**INFORMATIVE APPENDIX J  
ADDENDA DESCRIPTION INFORMATION**

ANSI/ASHRAE Standard 62.1-2010 incorporates ANSI/ASHRAE Standard 62.1-2007 and Addenda a, b, c, d, e, f, g, h, i, j, k, l, m, n, o, p, q, r, s, and t to ANSI/ASHRAE Standard 62.1-2007. Table J-1 lists each addendum and describes the way in which the standard is affected by the change. It also lists the ASHRAE and ANSI approval dates for each addendum.

**TABLE J-1 Addenda to ANSI/ASHRAE Standard 62.1-2007**

Addendum	Section(s) Affected	Description of Changes*	Approval Dates: • Standards Committee • ASHRAE BOD • ANSI
a	4.3 Documentation; 5.1 Natural Ventilation; 5.2 Ventilation Air Distribution; 5.4 Ventilation System Controls; 5.6.1 Location; 5.6.4 Snow Entrainment; 5.10.2 Exfiltration; 5.12.2 Finned-Tube Coil Selection for Cleaning; 5.13.2 Obstructions; 5.16 Buildings with Attached Parking Garages; 5.17 Air Classification and Recirculation	This addendum provides a general cleanup of Standard 62.1-2007, adding clarity and removing errors and inconsistencies. No significant new requirements were added.	June 21, 2008 June 25, 2008 June 26, 2008
b	Informative Appendices C, D and F	This addendum addresses compliance issues that may result from unclear wording or phrasing in Appendices C, D, and F.	June 23, 2007 June 27, 2007 June 28, 2007
c	6.2.1.1 Particulate Matter, 6.2.1.2 Ozone, and 9 References	This addendum updates Table 4-1 to include the NAAQS for PM <sub>2.5</sub> and inserts appropriate language into Section 6.2.1. The U.S. EPA changed to an eight-hour average ozone concentration as the basis for compliance with the NAAQS. Selection of a design value of 0.107 ppm or more (corresponding to Serious, Severe, or Extreme by the U.S. EPA) is based on limiting this requirement to the worst ambient air quality areas with regards to ozone. Requirement related to when ozone air-cleaning devices must operate is changed to adjust for the U.S. EPA policy change. The trigger point for requiring air-cleaning devices was lowered to 0.080 ppm.	June 20, 2009 June 24, 2009 July 22, 2009
d	Table 5-2 and Table 6-1	This addendum adds the following Occupancy Categories to Table 6-1: "Kitchens (cooking)" has been inserted under the subheading "Food and Beverage Service". "Banks" or "Bank Lobbies" has been inserted under the subheading "Miscellaneous Spaces" and "Breakrooms" has been inserted under the subheading "Office Buildings". "Sorting, Packing, Light Assembly" and "General Manufacturing (excludes heavy industrial and processes using chemicals) have been inserted under the subheading "Miscellaneous Spaces". Occupancy category, "Storage rooms (dry)" has been inserted in under "Office Buildings".	June 20, 2009 June 24, 2009 July 22, 2009
e	5.6.2 Rain Entrainment; 9 References	This addendum updates the references to industry standards and documents within the body of Standard 62.1-2007, and particularly in Section 9.	January 19, 2008 January 23, 2008 June 26, 2008
f	Table 6-1 Item Specific Note C	This addendum clarifies the meaning of "pool deck area" and associated outdoor airflow rate requirements.	January 19, 2008 January 23, 2008 June 26, 2008

**TABLE J-1 Addenda to ANSI/ASHRAE Standard 62.1-2007 (Continued)**

Addendum	Section(s) Affected	Description of Changes*	Approval Dates: • Standards Committee • ASHRAE BOD • ANSI
g	6.2.7 Dynamic Reset; 6.4 Design Documentation Procedures	This addendum provides additional information for demand-controlled ventilation (DCV) systems to augment Section 6.2.7 Dynamic Reset.	January 23, 2010 January 27, 2010 January 28, 2010
h	4.1 Regional Air Quality; Table 4-1 National Primary Ambient Air Quality Standards for Outdoor Air as Set by the U.S. Environmental Protection Agency; new Informative Appendix J	Table 4-1 has become out-of-date due to changes in the U.S. ambient air quality regulations. This addendum relocates Table 4-1 to a new informative appendix and makes appropriate wording changes in Section 4.1.	January 19, 2008 January 23, 2008 June 26, 2008
i	6.2.9 Ventilation in Smoking Areas	This addendum deletes Section 6.2.9.	June 20, 2009 June 24, 2009 July 22, 2009
j	8.1.2 Operation and Maintenance, 8.2 Operations and Maintenance Manual, and 8.3 Ventilation System Operation	This addendum to Section 8 clarifies when, at a minimum, the ventilation systems shall be operated.	January 24, 2009 January 28, 2009 January 29, 2009
k	General Note 2 of Table 6-1	This addendum corrects language in Note 2 of Table 6-1 (smoking) to make it consistent with terminology used elsewhere in the standard.	January 24, 2009 January 28, 2009 January 29, 2009
l	Informative Appendix D Acceptable Mass Balance Equations for use with Indoor Air Quality Procedure	This addendum modifies Informative Appendix D as follows: (1) Improve variable-name consistency with body of the standard and Appendix A. (2) Delete one figure, replace with two improved figures. (3) Delete "proportional" systems from Table D-1, since VAV systems with fixed-position outdoor air dampers are unlikely to meet the requirements of the standard and should be discouraged.	June 20, 2009 June 24, 2009 June 25, 2009
m	General Note 7 of Table 6-1 and Normative Appendix E Ventilation Rates for Health Care Facilities	This addendum removes ventilation requirements for healthcare spaces from the Standard since ventilation requirements for these types of spaces are covered in Standard 170-2008, "Ventilation of Health Care Facilities".	June 20, 2009 June 24, 2009 June 25, 2009
n	6. Ventilation, 6.1 General, 6.1.1 Ventilation Rate Procedures, 5.1 Natural Ventilation, 8.3 Ventilation System Operation	This addendum modifies Section 5.1 and 6.0 to relocate Natural Ventilation requirements into Section 6, to add prescriptive requirements for naturally ventilated systems, and to require both passive and mechanical ventilation (mixed-mode or hybrid) ventilation for most buildings in most climates.	June 20, 2009 June 24, 2009 June 25, 2009
o	6. Procedures, 6.4 Exhaust Ventilation, 8.3 Ventilation System Operation	This addendum moves the existing 6.2.8 and the corresponding Table 6-4 into a new Section 6.5 such that it applies to all spaces regardless of the method used to provide ventilation to the occupied spaces (Ventilation Rate Procedure, IAQ Procedure, Natural Ventilation).	June 20, 2009 June 24, 2009 June 25, 2009
p	5.6.1 Location and Table 5-1 Air Intake Minimum Separation Distance	This addendum addresses separation distance requirements between outdoor air intakes and other openings in buildings with respect to sources of contaminants and exhaust locations. To reduce the need for interpretation and judgment, building exhaust and relief airstreams are characterized using the Classes of Air already defined in the Standard rather than simple descriptions of the air quality.	June 20, 2009 June 24, 2009 July 22, 2009

**TABLE J-1 Addenda to ANSI/ASHRAE Standard 62.1-2007 (Continued)**

Addendum	Section(s) Affected	Description of Changes*	Approval Dates: • Standards Committee • ASHRAE BOD • ANSI
q	Informative Appendix B Summary of Selected Air Quality Guidelines	Designers who choose to use the IAQ Procedure must identify contaminants of concern. Table B-3 lists some volatile organic compounds which designers might want to consider as possible contaminants of concern. Also, the impact of mixtures of some contaminants on humans may be considered to be “additive” (this is a basic assumption in the Ventilation Rate Procedure). To encourage designers to consider “additivity” when applying the IAQ Procedure, some guidance from the ACGIH has been included in the informative text. Appendix B is informative.	January 23, 2010 January 27, 2010 January 28, 2010
r	6.1.2 IAQ Procedure; Section 6.3 Indoor Air Quality (IAQ) Procedure	This addendum modifies the IAQ procedure in Section 6.3 and its description in Section 6.1. It addresses compliance issues that may result from unclear wording or phrasing. It makes a mass balance analysis a required part of the IAQ procedure. This addendum requires that performance of IAQ procedure designed systems be tested similar to the requirements to test VRP designed systems or that it be based on the tested performance of a design for a similar zone, with added requirements for determining whether a zone is similar.	January 23, 2010 January 27, 2010 January 28, 2010
s	Table 6-1 Minimum Ventilation Rates in Breathing Zone	Based on committee-member experience, “shipping/receiving” areas and “warehouses” require a minimum outdoor airflow rate per person as well as a minimum per unit area rate, and “coin-operated laundries” need a higher minimum outdoor airflow rate per unit area than previously published.	June 20, 2009 June 24, 2009 June 25, 2009
t	3 Definitions; 6.2 Ventilation Rate Procedure; Table 6-3 System Ventilation Efficiency; Normative Appendix A Multiple-Zone Systems	This addendum modifies normative Appendix A, and associated Section 6.2 requirements, as follows: (1) It reduces compliance issues that may result from unclear wording or phrasing, especially for VAV systems. (2) It improves nomenclature consistency between the body of the standard and the appendix. (3) It moves key equations from textual definitions to the body of the Appendix. (4) It clarifies the design conditions (including minimum expected discharge airflow and highest expected system primary airflow) used to calculate worst-case intake airflow for multiple-zone recirculating systems.	January 23, 2010 January 27, 2010 January 28, 2010

\* These descriptions may not be complete and are provided for information only.

**NOTE**  
**Approved addenda, errata, or interpretations for this standard can be downloaded free of charge from the ASHRAE Web site at [www.ashrae.org/technology](http://www.ashrae.org/technology).**

## NOTICE

### INSTRUCTIONS FOR SUBMITTING A PROPOSED CHANGE TO THIS STANDARD UNDER CONTINUOUS MAINTENANCE

This standard is maintained under continuous maintenance procedures by a Standing Standard Project Committee (SSPC) for which the Standards Committee has established a documented program for regular publication of addenda or revisions, including procedures for timely, documented, consensus action on requests for change to any part of the standard. SSPC consideration will be given to proposed changes within 13 months of receipt by the manager of standards (MOS).

Proposed changes must be submitted to the MOS in the latest published format available from the MOS. However, the MOS may accept proposed changes in an earlier published format if the MOS concludes that the differences are immaterial to the proposed change submittal. If the MOS concludes that a current form must be utilized, the proposer may be given up to 20 additional days to resubmit the proposed changes in the current format.

### ELECTRONIC PREPARATION/SUBMISSION OF FORM FOR PROPOSING CHANGES

An electronic version of each change, which must comply with the instructions in the Notice and the Form, is the preferred form of submittal to ASHRAE Headquarters at the address shown below. The electronic format facilitates both paper-based and computer-based processing. Submittal in paper form is acceptable. The following instructions apply to change proposals submitted in electronic form.

Use the appropriate file format for your word processor and save the file in either a recent version of Microsoft Word (preferred) or another commonly used word-processing program. Please save each change proposal file with a different name (for example, "prop01.doc," "prop02.doc," etc.). If supplemental background documents to support changes submitted are included, it is preferred that they also be in electronic form as word-processed or scanned documents.

ASHRAE will accept the following as equivalent to the signature required on the change submittal form to convey non-exclusive copyright:

Files attached to an e-mail:	Electronic signature on change submittal form (as a picture; *.tif, or *.wpg).
Files on a CD:	Electronic signature on change submittal form (as a picture; *.tif, or *.wpg) or a letter with submitter's signature accompanying the CD or sent by facsimile (single letter may cover all of proponent's proposed changes).

Submit an e-mail or a CD containing the change proposal files to:  
Manager of Standards  
ASHRAE  
1791 Tullie Circle, NE  
Atlanta, GA 30329-2305  
E-mail: [change.proposal@ashrae.org](mailto:change.proposal@ashrae.org)  
(Alternatively, mail paper versions to ASHRAE address or fax to 404-321-5478.)

The form and instructions for electronic submittal may be obtained from the Standards section of ASHRAE's Home Page, [www.ashrae.org](http://www.ashrae.org), or by contacting a Standards Secretary, 1791 Tullie Circle, NE, Atlanta, GA 30329-2305.  
Phone: 404-636-8400. Fax: 404-321-5478. E-mail: [standards.section@ashrae.org](mailto:standards.section@ashrae.org).



## FORM FOR SUBMITTAL OF PROPOSED CHANGE TO AN ASHRAE STANDARD UNDER CONTINUOUS MAINTENANCE

**NOTE:** Use a separate form for each comment. Submittals (Microsoft Word preferred) may be attached to e-mail (preferred), submitted on a CD, or submitted in paper by mail or fax to ASHRAE, Manager of Standards, 1791 Tullie Circle, NE, Atlanta, GA 30329-2305. E-mail: [change.proposal@ashrae.org](mailto:change.proposal@ashrae.org). Fax: +1-404/321-5478.

### 1. Submitter:

Affiliation:

Address: \_\_\_\_\_ City: \_\_\_\_\_ State: \_\_\_\_\_ Zip: \_\_\_\_\_ Country: \_\_\_\_\_

Telephone: \_\_\_\_\_ Fax: \_\_\_\_\_ E-Mail: \_\_\_\_\_

I hereby grant the American Society of Heating, Refrigerating and Air-Conditioning Engineers, Inc. (ASHRAE) the non-exclusive royalty rights, including non-exclusive rights in copyright, in my proposals. I understand that I acquire no rights in publication of the standard in which my proposals in this or other analogous form is used. I hereby attest that I have the authority and am empowered to grant this copyright release.

Submitter's signature: \_\_\_\_\_ Date: \_\_\_\_\_

### ***All electronic submittals must have the following statement completed:***

I (*insert name*) \_\_\_\_\_, through this electronic signature, hereby grant the American Society of Heating, Refrigerating and Air-Conditioning Engineers (ASHRAE) the non-exclusive royalty rights, including non-exclusive rights in copyright, in my proposals. I understand that I acquire no rights in publication of the standard in which my proposals in this or other analogous form is used. I hereby attest that I have the authority and am empowered to grant this copyright release.

### 2. Number and year of standard:

### 3. Page number and clause (section), subclause, or paragraph number:

4. I propose to:                     Change to read as follows                     Delete and substitute as follows  
(*check one*)                     Add new text as follows                     Delete without substitution

Use underscores to show material to be added (added) and strike through material to be deleted (~~deleted~~). Use additional pages if needed.

### 5. Proposed change:

### 6. Reason and substantiation:

7. Will the proposed change increase the cost of engineering or construction? If yes, provide a brief explanation as to why the increase is justified.

Check if additional pages are attached. Number of additional pages: \_\_\_\_\_

Check if attachments or referenced materials cited in this proposal accompany this proposed change. Please verify that all attachments and references are relevant, current, and clearly labeled to avoid processing and review delays. *Please list your attachments here:*



**POLICY STATEMENT DEFINING ASHRAE'S CONCERN  
FOR THE ENVIRONMENTAL IMPACT OF ITS ACTIVITIES**

ASHRAE is concerned with the impact of its members' activities on both the indoor and outdoor environment. ASHRAE's members will strive to minimize any possible deleterious effect on the indoor and outdoor environment of the systems and components in their responsibility while maximizing the beneficial effects these systems provide, consistent with accepted standards and the practical state of the art.

ASHRAE's short-range goal is to ensure that the systems and components within its scope do not impact the indoor and outdoor environment to a greater extent than specified by the standards and guidelines as established by itself and other responsible bodies.

As an ongoing goal, ASHRAE will, through its Standards Committee and extensive technical committee structure, continue to generate up-to-date standards and guidelines where appropriate and adopt, recommend, and promote those new and revised standards developed by other responsible organizations.

Through its *Handbook*, appropriate chapters will contain up-to-date standards and design considerations as the material is systematically revised.

ASHRAE will take the lead with respect to dissemination of environmental information of its primary interest and will seek out and disseminate information from other responsible organizations that is pertinent, as guides to updating standards and guidelines.

The effects of the design and selection of equipment and systems will be considered within the scope of the system's intended use and expected misuse. The disposal of hazardous materials, if any, will also be considered.

ASHRAE's primary concern for environmental impact will be at the site where equipment within ASHRAE's scope operates. However, energy source selection and the possible environmental impact due to the energy source and energy transportation will be considered where possible. Recommendations concerning energy source selection should be made by its members.

## About ASHRAE

The American Society of Heating, Refrigerating and Air-Conditioning Engineers (ASHRAE), founded in 1894, is an international organization of some 50,000 members. ASHRAE fulfills its mission of advancing heating, ventilation, air conditioning, and refrigeration to serve humanity and promote a sustainable world through research, standards writing, publishing, and continuing education.

For more information or to become a member of ASHRAE, visit [www.ashrae.org](http://www.ashrae.org).

To stay current with this and other ASHRAE standards and guidelines, visit [www.ashrae.org/standards](http://www.ashrae.org/standards).

— . —

ASHRAE has two collections of standards and guidelines available on CD that include one year of unlimited access to download monthly updates, including addenda, errata, and interpretations. *ASHRAE Standards and Guidelines* contains the complete library, and *Essential Standards* contains ASHRAE's 12 most referenced standards and guidelines. Both include the User's Manuals for Standard 90.1 and Standard 62.1. For more information on these products, visit the Standards and Guidelines section of the ASHRAE bookstore at [www.ashrae.org/bookstore](http://www.ashrae.org/bookstore).

### IMPORTANT NOTICES ABOUT THIS STANDARD

**To ensure that you have all of the approved addenda, errata, and interpretations for this standard, visit [www.ashrae.org/standards](http://www.ashrae.org/standards) to download them free of charge.**

**Addenda, errata, and interpretations for ASHRAE standards and guidelines will no longer be distributed with copies of the standards and guidelines. ASHRAE provides these addenda, errata, and interpretations only in electronic form in order to promote more sustainable use of resources.**